

Zelio Logic 2

Smart Relay

User's Guide

January 2004



Preliminary Advice on Installing Smart Relays

Power down the device.

Take all necessary measures to avoid unwanted relay triggering.

Check to ensure that no voltage is present.

Make the necessary ground and short circuit connections.

Always follow the instructions stated in this user's guide.

Remember that only qualified personnel are authorized to implement the smart relay.

Automation and control devices must be installed so that they are protected against any risk of involuntary actuation.

It is essential to ensure that all control system connections meet applicable safety standards.

Fluctuations or variations in the supply voltage should not exceed the tolerance thresholds stated in the technical characteristics, as they may cause operating failures and lead to potentially dangerous situations.

Take care to meet the standards that apply to emergency stop systems in order to avoid potentially dangerous situations. Ensure that releasing the emergency stop system does not cause the automated system to suddenly restart.

Take all necessary measures to ensure that an application interrupted by a break in the supply voltage can continue correctly and also ensure that no dangerous states, no matter how brief, may occur.

Contents

	Page
You would like to know how your new smart relay works and discover its main characteristics.	1 - Discovering the Smart Relay 4
You would like to know all of the smart relay's options.	2 - Description of Menus 16
You would like to know all of the smart relay's configuration options.	3 - Configuration Menu 36
You would like to know all of the elements in the Ladder diagram that are recognized and used by the smart relay.	4 - Automation Functions 48
You would like to learn to enter a complete Ladder diagram using the smart relay.	5 - Entering Ladder Diagrams 94
You require detailed information on, for example, implementing a Ladder diagram using the smart relay.	6 - Implementing a Basic Application 104
You would like to know what smart relay control capabilities are offered during operation and how power breaks are handled.	7 - Debugging 120
You would like to improve your understanding of the smart relay using a complete example.	8 - Application Example 130
You have an operating problem and you would like to find the solution.	9 - Troubleshooting 136
You would like to backup, transfer or duplicate your application.	10 - To Load an Application Stored in the Backup Memory onto the Module 140
You are looking for tools to assist with application design: entry forms.	Appendix 145
You are looking for a specific word.	Index 149

Chapter 1 - Contents

Powering up and Discovering the Smart Relay

This Chapter covers the following subjects:

1. Presentation	5
2. Characteristics and Connections	7
3. Command Keys	8
4. Examples	11
5. Differences due to the Programming Language Used: LD / FBD	15

1. Presentation

Smart relays are designed to simplify the electrical wiring of intelligent solutions. A smart relay is very simple to implement. Its flexibility and its high performance allows users to save significant amounts of time and money.

This User's Guide is intended for people who do not have an in-depth knowledge of automation systems and who would like to be able to implement smart relays.

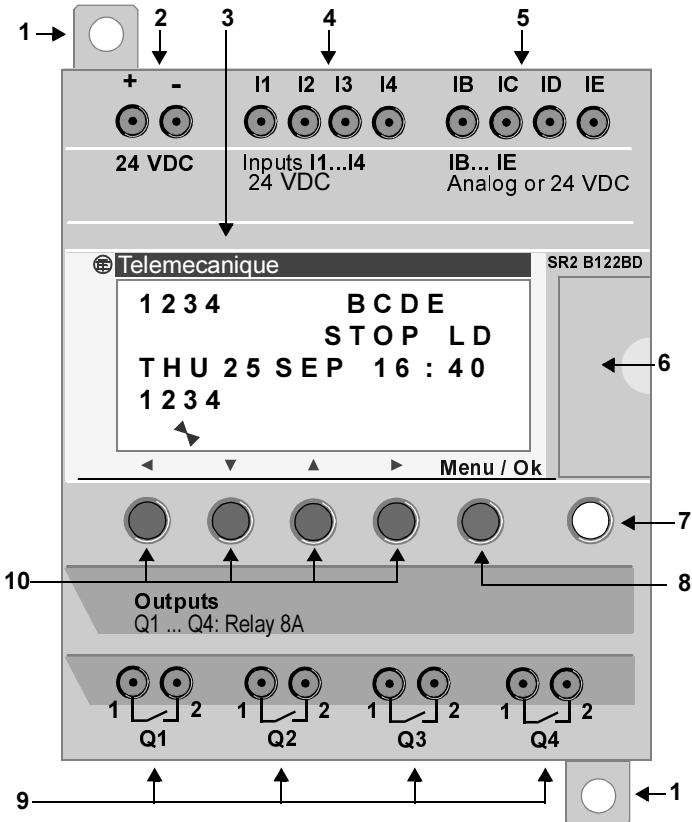

1. Presentation

Description of the front panel of the relay

Reference	Description
1	Retractable mounting feet.
2	Screw terminal block for the power supply.
3	LCD, 4 lines, 18 characters
4	Screw terminal block for inputs
5	Screw terminal block for 0-10 Volt analog inputs usable in discrete mode on some models
6	Connector for backup memory or PC connection cable
7	Shift key
8	Selection and validation key
9	Relay output screw terminal block
10	Arrow keys or after first configuring them, Z pushbuttons

Description of the LCD

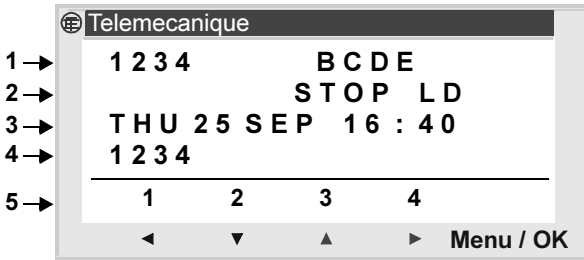

Reference	Description
1	Input status display (B...E represent the analog inputs*)
2	Display of the operating mode (RUN/STOP) and programming mode (LD/FBD)
3	Display of the date (day and time for products with clock)
4	Output status display
5	Contextual menus / pushbuttons / icons indicating the operating modes

* Each analog input is also usable in discrete I/O mode

2. Characteristics and Connections

Connecting DC smart relays

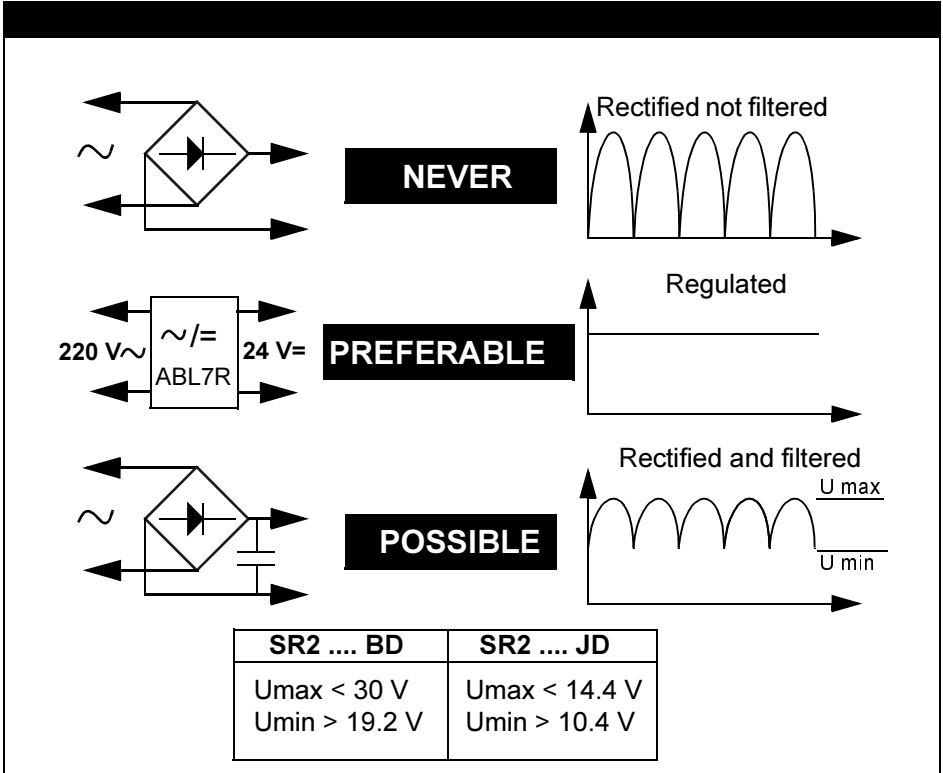

3. Command Keys

Description

The keys located on the front of the smart relay are used to configure, program and control the application and monitor the application's progress.

The LCD screen is lit for 30 seconds when the user presses any of the buttons on the front panel.

Illustration

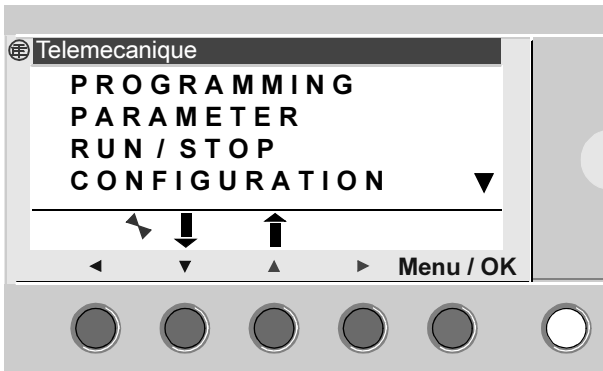

Shift key



Corresponds to the white key located on the right side of the LCD screen.

When the "Shift" key is pressed, a contextual menu is displayed above the other Z keys (ins, del, Param, etc.).

Menu / OK key



Corresponds to the blue button located under the LCD.

This key is used for all validations: menu, sub-menu, program, parameter, etc.

3. Command Keys

Navigation keys or Z keys



The Z keys are the gray keys in a line from left (Z1) to right (Z4) and located under the LCD. The arrows indicating the movement direction associated with navigation are marked above the keys.

The navigation keys are used to move up, down, left and right.

The position on the screen appears as a flashing area:

- ◆ Square for a position that corresponds to a contact (only in programming mode),
- ◆ Circle for a coil (only in programming mode).

Note: When the buttons can be used for actions other than navigation, a line from the contextual menu is displayed (Example: 1, 2, 3 and 4 as Zx key entries).

Contextual Menus

When the cursor is placed on a modifiable parameter, if the **Shift** key is pressed, a contextual menu appears.

Illustration



Use of the contextual menu functions:

- ◆ **+ / -:** used to scroll through the various possible values of the selected field (types of inputs, outputs, automation functions, numbers, numerical values, etc),
- ◆ **Ins.:** Inserts a line when the cursor is over a parameter or inserts an automatic function when the cursor is over a blank space
- ◆ **Del.:** Clears the specified element or the line, if it is empty
- ◆ **Param.:** Displays the parameters screen specific to the automatic function (visible only if the automatic function has a parameter)

3. Command Keys



◆ ← ↑ ↓ →: Direction of the connection trace (visible only if the cursor is over a link box)

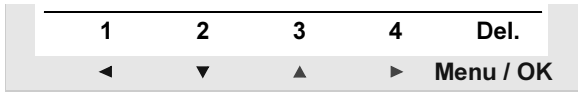

◆ 1 2 3 4: this line appears when the keys are used as Zx key-type inputs in a program.





◆ ← →: Selection of parameters to be modified.
◆ + / -: Allows you to scroll through the different possible values for the selected parameter.



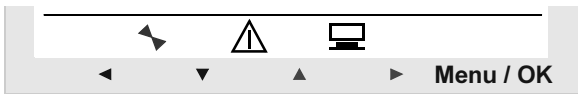

◆ The key indicates that the program is password-protected.



◆  Indicates the state of the module. In RUN it is in motion, in STOP it is immobile.
◆  Indicates that faults have appeared (see FAULT menu).
◆  Indicates that the module is connected to the workshop.

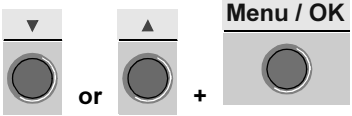
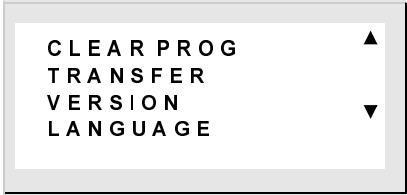

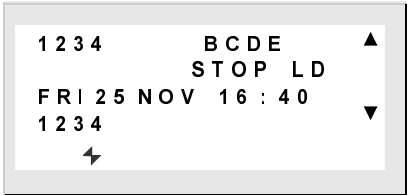

4. Examples

Description/Action	Display
<p>Select and validate the language.</p>  <p>(the selection is highlighted by the blinking of the text)</p>	 <p>The Menu / OK button is used to confirm the choice of the new language. The display returns to the MAIN menu (STOP mode).</p>
<p>Return to the INPUT-OUTPUT screen.</p> 	 <p>The Menu / OK button is used to confirm the choice of the new language.</p>

4. Examples

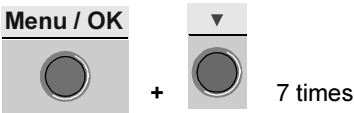

This sub-section details how to use the smart relay's keys. This does not apply to Blind modules.

Example 1: Language selection (same procedure regardless of product)



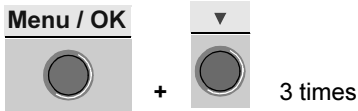
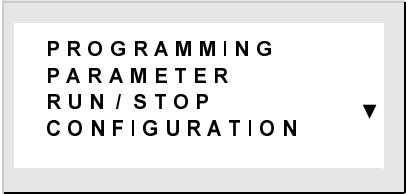
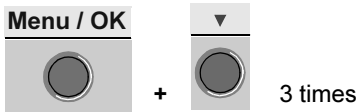
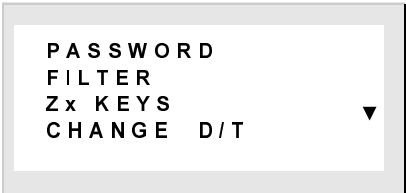

Description/Action	Display
<p>Powering-up</p>	 <p>On powering-up, the INPUT-OUTPUT screen is displayed. (See Chapter 2 - Description of menus/ INPUT-OUTPUT screen) By default, the selected language is English.</p>
<p>Enter the MAIN menu, and go to the language configuration menu: LANGUAGE</p> 	
<p>Enter the language configuration menu.</p> 	 <p>The activated option is indicated by a black diamond.</p>

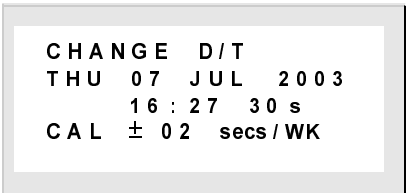
4. Examples

Example 2: Changing the date and time when first powered up or after a long lasting power break.

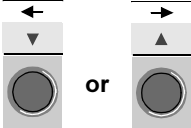
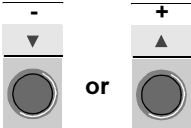
Description/Action	Display
<p>From the INPUT-OUTPUT screen, enter the MAIN menu, then go to the CONFIGURATION menu</p> 	
<p>Enter the CONFIGURATION menu, and go to the CHANGE D/T sub-menu</p> 	
<p>Enter the date and time configuration menu</p> 	

4. Examples

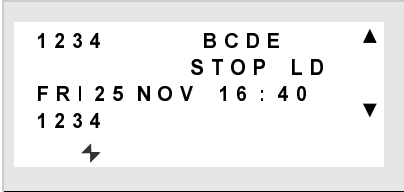
Description/Action	Display
<p>Select the parameter to modify using the navigation keys (the selection is highlighted by the blinking of the parameter):</p>  <p>Modify the parameter using the navigation keys:</p>  <p>then confirm with Menu / OK</p> 	 <p>The Menu / OK button is used to confirm the modifications. The display returns to the MAIN menu (STOP mode).</p>
<p>Return to the INPUT-OUTPUT screen.</p> 	 <p>The Menu / OK button is used to confirm the choice of the new language.</p>

5. Differences due to the Programming Language Used: LD / FBD

Certain functions or menus are specific to the type of programming language used: LD or FBD.

Functions accessible according to the mode used: LD / FBD

Function	LD	FBD
Programming an application from the front panel of the relay.	X	
Setting up parameters for automation functions	X	X
Controlling the application	X	X
Monitoring the progress of the application	X	X

Functions accessible according to the mode used: LD and FBD

Menu	LD	FBD
PROGRAMMING (STOP)	X	
MONITORING (RUN)	X	
PARAMETER (mode-specific)	X	X
RUN / STOP	X	X
CONFIGURATION (STOP)		
PASSWORD	X	X
FILTER	X	X
Zx KEYS	X	
CHANGE D/T	X	X
CHANGE SUMM/WINT	X	X
WATCHDOG CYCLE	X	X
CLEAR PROG. (STOP)	X	
TRANSFER	X	X
VERSION	X	X
LANGUAGE	X	X
FAULT	X	X

Chapter 2 - Contents

Description of Menus

1. Menu Presentation	17
2. INPUTS-OUTPUTS Screen	18
3. TEXT and DISPLAY screen	19
4. PROGRAMMING Menu	21
5. PARAMETER Menu	22
6. MONITORING Menu	25
7. RUN/STOP Menu	26
8. CONFIGURATION Menu	27
9. CLEAR PROGRAM Menu	28
10. TRANSFER Menu	29
11. LANGUAGE Menu	31
12. VERSION Menu	32
13. FAULT Menu	33

1. Menu Presentation

Description

These functions are grouped in a main menu.

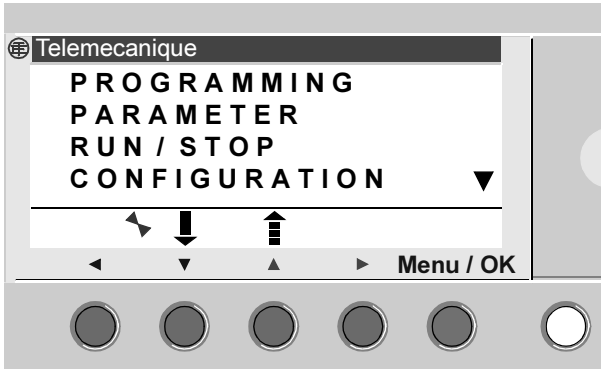

The line blinks to show where you are positioned.

An upwards triangle ▲ shows that there are more options available if you scroll up, while a downwards triangle ▼ shows that there are more options available if you scroll down ▼ .

Managing Menu

The **INPUTS-OUTPUTS** screen is displayed by default whether the mode is in **LD** or **FBD**.

Pressing the **Menu/OK** key switches the display from the **INPUTS-OUTPUTS** screen to the **MAIN** menu.

The menu on the first row which is selected by default (flashing). The arrow keys can be used to place the cursor over the other menus.

Press the blue **Menu/OK** key to display the screen corresponding to the selected menu or move onto the first sub-menu. OK

Note: The different menu functions vary according to the programming language used: **LD** or **FBD**.
When a specificity exists, it is specified.

2. INPUTS-OUTPUTS Screen

Description

This is the highest level interface, if no display function is active: **TEXT** (LD) or **DISPLAY** (FBD).

This screen is displayed by default whatever the programming type: **LD** or **FBD** and the mode: **STOP** or **RUN**.

Illustration:

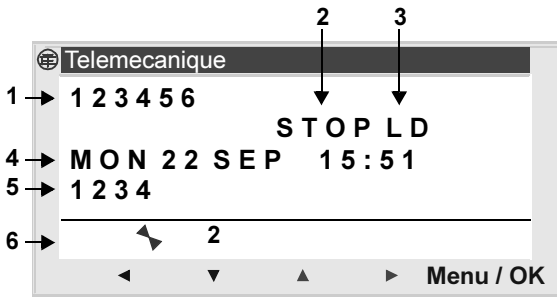

The INPUTS-OUTPUTS screen can be used to view:

- ◆ Input status: 1 to 9, A to P (1),
- ◆ Operating mode: RUN/STOP (2),
- ◆ Type in use: LD/FBD (3),
- ◆ Date and time for products with a clock (4),
- ◆ Output status: 1 to 9, A to G (5).
- ◆ Z push buttons: 1 to 4 (6).

In Simulation mode or Monitoring mode when the program is in **RUN**, the active states of the Inputs/Outputs are indicated in reverse video.

Pressing the **Shift** and **Menu/OK** keys in order and simultaneously switches the screen display from INPUTS-OUTPUTS to **TEXT** (LD) or **DISPLAY** (FBD).

Access to the main menu

Pressing the **Menu/OK** key switches the display from the INPUTS-OUTPUTS screen to the main menu.

3. TEXT and DISPLAY screen

Description

The display functions are used to display text or a numerical value (current value, preset value, etc.) on the LCD instead of the **INPUTS-OUTPUTS** screen:

- ◆ In **LD** mode: a **TEXT** function is active,
- ◆ In **FBD** mode: a **DISPLAY** function is active.

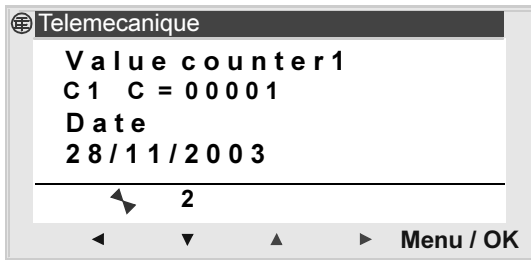

If several display functions are active simultaneously, we see the following:

- ◆ In **LD** mode: only the last block to be activated is displayed,
- ◆ In **FBD** mode: the superposition of all of the FBD **DISPLAY** screens is displayed.

Note: The display functions can only be programmed using the programming workshop (refer to the Zelio Soft 2 on-line help manual for further information).

Pressing the **Shift** and **Menu/OK** keys in order and simultaneously switches the screen display from **TEXT** (**LD**) or **DISPLAY** (**FBD**) to **INPUTS-OUTPUTS**.

3. TEXT and DISPLAY screen

Authorized modifications

All parameters for which the **Authorized modification** option is enabled can be modified from the front panel of the module.

Description of the modification procedure for displayed values:

Step	Description
1	Press the Shift key (white key) to display the contextual menu. Result: Param is displayed at the bottom of the screen.
2	Press the → key (without releasing the Shift key) to display the contextual menu. Result: The parameter which can be modified flashes and the following contextual menu is displayed: 
3	Select the parameter to be modified using the arrow keys ← and → from the contextual menu (the value which are available for modification flash).
4	Modify the value of the parameter with the + (↑) and - (↓) keys from the contextual menu.
5	Confirm the modifications by pressing the Menu/OK key. Result: the display returns to the INPUTS-OUTPUTS screen or the TEXT / DISPLAY screen.

4. PROGRAMMING Menu

Note: This menu is specific to LD (STOP mode).

This function lets the user enter the Ladder diagrams that will work on the smart relay.

This program is only written using a Ladder diagram LD .

Information on how to program a Ladder diagram is given in the chapter:
Chapter 5 - Entering Ladder Diagrams.

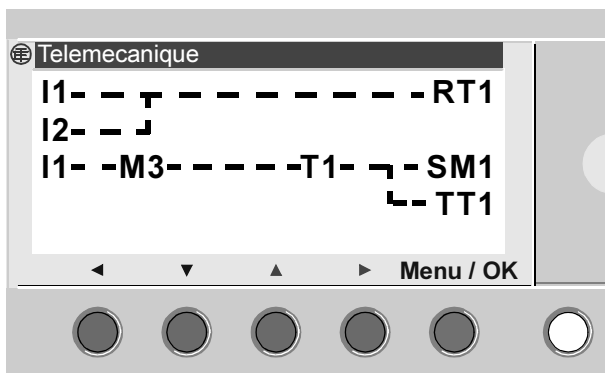

Once the modifications are enabled, the display returns to the MAIN menu.

Note: This function may be password protected.

5. PARAMETER Menu

Description

This menu allows the user to enter and modify the application parameters directly on the screen using the relay keys. This function can be accessed in the two modes: **LD** and **FBD**, but the contents will be specific to the mode used.

If there are parameters to display (and where these are not locked), they are listed in the window; otherwise a **NO PARAMETERS** message appears.

LD Mode

Functions with parameters in LD mode:

- ◆ Auxiliary relays (latching),
- ◆ Discrete Outputs (latching),
- ◆ Clocks,
- ◆ Analog comparators,
- ◆ Timers,
- ◆ Counters,
- ◆ Fast counters.

Only those functions used in the program and with parameters are listed in the **PARAMETERS** menu.

All of the functions that have parameters are listed in the **PARAMETER** menu.

Parameter modification procedure:

Steps	Description
1	Place the cursor over the PARAMETERS menu in the main menu (PARAMETERS flashing) and confirm by pressing the Menu/OK button. Result: the parameters window opens to the first parameter.
2	Select the function to modify. To access the required function, scroll through all the functions (navigation keys ↑ and ↓) until you reach the right one.
3	Select the parameter to modify. Use the ← and → keys to move to the parameter to be modified.

5. PARAMETER Menu

FBD Mode

Functions with parameters in LD mode:

- ◆ Numerical Constant-Type Inputs,
- ◆ Clocks,
- ◆ Gain,
- ◆ Timers: TIMER A/C, TIMER B/H, TIMER Li,
- ◆ Counter: PRESET COUNT,
- ◆ Fast counters,
- ◆ CAM block,

Accessing parameters for the FBD blocks requires that the user know and enter the block number. This number appears on the wiring sheet in the upper right corner of the block.

If there are parameters to display (and where these are not locked), they are listed in the window; otherwise a **NO PARAMETERS** message appears.

Parameter modification procedure:

Steps	Description
1	Place the cursor over the PARAMETERS menu in the main menu (PARAMETERS flashing) and confirm by pressing the Menu/OK button. Result: the parameters window opens to the first parameter.
2	Select the function to modify. To access the required function, scroll through the function block numbers (navigation keys ↑ and ↓) until you reach the right one.
3	Select the parameter to modify. The ← and → keys can be used to place the cursor over the parameter to modify.
4	Modify the parameter using the + and - keys (↑ and ↓) of the contextual menu.
5	Validate the modifications by pressing Menu/OK , which opens the validation window.
6	Confirm again twice by pressing Menu/OK to save. Result: the display returns to the INPUTS-OUTPUTS screen in RUN mode and to the MAIN menu in STOP mode.

5. PARAMETER Menu

Steps	Description
4	Modify the parameter using the + and - keys (↑ and ↓) of the contextual menu.
5	Validate the modifications by pressing Menu/OK , which opens the validation window.
6	Confirm again twice by pressing Menu/OK to save. Result: the display returns to the INPUTS-OUTPUTS screen in RUN mode and to the MAIN menu in STOP mode.

Parameters (in RUN mode)

It is therefore possible to modify dynamic parameters in RUN mode as long as they are not locked.

The modifications can be made:

- ◆ From the PARAMETER menu,
- ◆ From the MONITORING menu: move to the function to be modified using the arrow keys (←↑↓→) and open the parameters window from the contextual menu (Shift key).

6. MONITORING Menu

Description

Note: Accessible in LD / RUN mode only.

MONITORING mode is used to dynamically display the state of smart relay input/output.

In this mode the wiring diagram appears as it does in the **PROGRAMMING** menu (module in STOP mode), but appear in reverse video when inputs or outputs are activated (white on black background).

Illustration:



This mode allows the user to dynamically modify the value of the parameters of the automation functions if they are unlocked.

Modifying parameters

To modify the parameters, simply:

Steps	Description
1	Use the arrow keys to move to the element you would like to modify: step 1 of the procedure element entry .
2	Press the Shift and Param keys at the same time to open the parameters window.
3	Use the arrow keys to move to the modifiable parameter fields: ←→.
4	Change the parameter value using the + and - keys.
5	Validate the modifications by pressing Menu/OK , which opens the validation window. Validate Menu/OK again to save the modifications.
6	Confirm again with Menu/OK . Result: return to the parameter screen.
7	Confirm again with Menu/OK . Result: the display is set to the INPUTS-OUTPUTS screen.

7. RUN/STOP Menu

Description

This function lets the user start or stop the program contained in the smart relay:

- ◆ **STOP**: the program is stopped, the outputs are deactivated, the current values (counters, timers, etc.) are reset to zero (if the latching option is not activated).
- ◆ **RUN**: The program is executed.

Note: When STOP switches to RUN, the program is initialized.

Illustration:

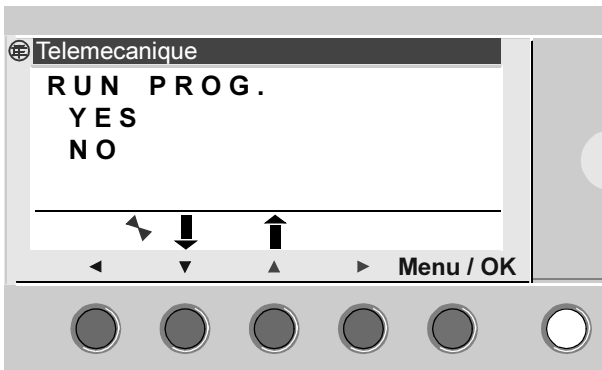

When opened, the interface offers the user the choice that is complementary to the current state : YES is always flashing.

If the program is in mode:

- ◆ **STOP**: RUN PROG. is proposed,
- ◆ **RUN**: STOP PROG. is proposed.

The $\uparrow\downarrow$ navigation keys are used to change the selection.

When the mode has been validated with the **Menu/OK** key, the display moves to the **INPUT-OUTPUT** screen.

8. CONFIGURATION Menu

Description

The configuration menu is made up of the following options:

- ◆ PASSWORD
- ◆ FILTER:
- ◆ Zx KEYS
- ◆ CHANGE D/T
- ◆ CHANGE SUMM/WINT
- ◆ WATCHDOG CYCLE

Note: If the program is password-protected, (key displayed in the contextual menu), the user must enter the password before any action can take place in the sub-menus.

The various configuration menu options are detailed in the chapter:
Chapter 3 - Configuration Menu.

9. CLEAR PROGRAM Menu

Description

Note: Only accessible in **LD mode**.

This function allows the entire program to be cleared.

Note: If the program is protected (key displayed), the user must enter a password before being able to clear the program.

Clearing the program

When it is opened, the **NO** choice is selected by default.

Procedure:

<i>Steps</i>	<i>Description</i>
1	Select YES using the ↑ and ↓ navigation keys.
2	Validate the clear command by pressing Menu/OK . Result: the display returns to the MAIN menu.

10. TRANSFER Menu

Description

This function is used to:

- ◆ Load the application contained in the module into the backup memory,
- ◆ Load a program into the module from the backup memory.

The program can then be loaded onto another module from this backup memory.

Illustration

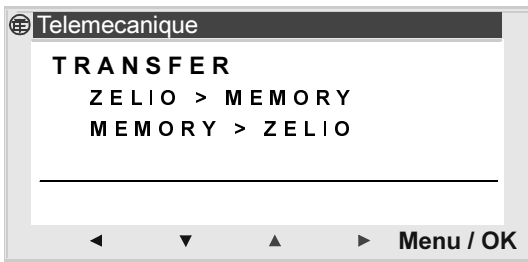

Note: The backup memory is available as an option.

Note: If the program is protected (key displayed), the user must enter a password before being able to back up the program.

Note: If an application is already present in the backup memory, it will be overwritten by the new transfer (no test is performed to check the memory is free).

10. TRANSFER Menu

Transfer module → Backup memory

Transfer procedure:

Steps	Description
1	Select the transfer type: ZELIO>MEMORY using the arrow keys ↑ ↓.
2	Confirm the transfer command with the Menu/OK key. (Enter the password if the program is password-protected).
3	Wait until the transfer is complete. The following is displayed: > > MEMORY then TRANSFER. OK when the transfer is complete.
4	Confirm a second time by pressing Menu/OK to exit the menu. Result: the display returns to the INPUTS-OUTPUTS screen in RUN mode and to the MAIN menu in STOP mode.

Backup Memory Transfer → Module

Transfer procedure:

Steps	Description
1	Select the transfer type: MEMORY>ZELIO using the arrow keys ↑ ↓.
2	Confirm the transfer command with the Menu/OK key.
3	Wait until the transfer is complete. The following is displayed: > > MODULE then TRANSFER. OK when the transfer is complete.
4	Confirm a second time by pressing Menu/OK to exit the menu. Result: the display returns to the INPUTS-OUTPUTS screen in RUN mode and to the MAIN menu in STOP mode.

Possible Errors

◆ **No backup memory**

Error message: TRANSFER ERROR: NO MEMORY

◆ **Configuration of program to be transferred incompatible with hardware configuration**

Error message: TRANSFER ERROR: CONFIG INCOMPAT (hardware or software reference numbers)

Refer to the FAULT menu to consult the error number and clear it.

11. Language Menu

Description

This function lets the user choose the language used by the smart relay.

All messages can be displayed in six languages:

- ◆ English
- ◆ French
- ◆ German
- ◆ Italian
- ◆ Spanish
- ◆ Portuguese

Illustration

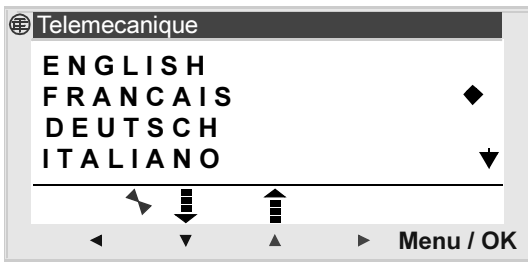

Language selection

The current language is shown by the selection symbol (black lozenge symbol).

Language selection procedure:

Steps	Description
1	Select the language using the navigation keys: ↓↑ (the selection flashes).
2	Confirm with Menu / OK . Result: the display returns to the INPUTS-OUTPUTS screen in RUN mode and to the MAIN menu in STOP mode.

12. VERSION Menu

Description

This function lets the user precisely identify the version of all of the system components:

- ◆ Hardware type
- ◆ Firmware
- ◆ FBD functions
- ◆ LD functions

Illustration

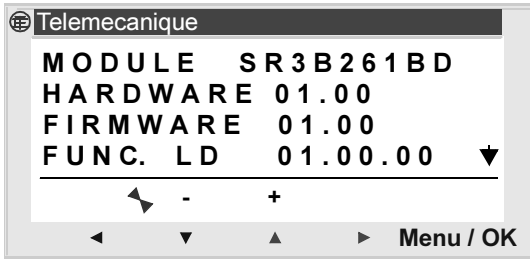

This information is available for the module, as well as for the extensions connected.

An arrow symbol located at the bottom right indicates that there are extension(s) connected to the module.

Illustration

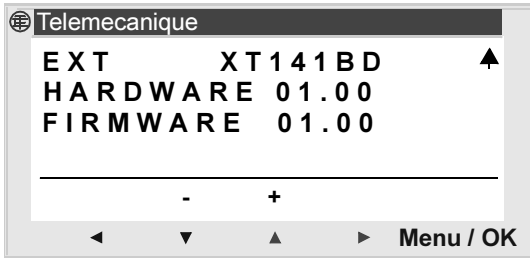

To quit, press the **Menu/OK** button, the display returns to the INPUTS-OUTPUTS screen in RUN mode and to the MAIN menu in STOP mode.

13. FAULT Menu

Description

This function allows the number of faults or warnings detected by the relay's firmware (watchdog overflow, cycle time too high, etc.) to be displayed.

Illustration

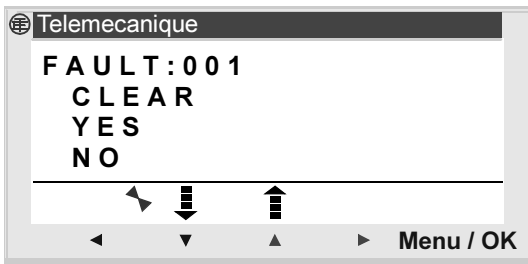

Reset to Zero of the Fault Counter

This menu is used to clear the errors, as indicated by the message: **DELETE**.

Procedure:

Steps	Description
1	Select YES / NO using the ↑ and ↓ navigation keys.
2	Confirm the clear command by pressing the Menu/OK key. Result: the display returns to the INPUTS-OUTPUTS screen in RUN mode and to the MAIN menu in STOP mode.

Description of errors

Number	Type of error
00	No faults
01	Fault in writing to EEPROM This fault defines transfer problems between the memory cartridge and the controller. If the fault occurs frequently, contact the after-sales service.
02	Fault in writing to the clock If the fault occurs frequently, contact the after-sales service.

13. FAULT Menu

Number	Type of error
04	<p>Overload on transistor outputs (warning)</p> <p>Once a transistor output reaches a temperature of 170°C, the group of 4 outputs to which it belongs is deactivated.</p> <p>To make this group of outputs operational, the cause of the over current (short-circuit, etc.) must first be deleted, and then the fault cleared from the FAULT menu.</p>
50	<p>Module firmware is damaged</p> <p>Reload the firmware on the module and the user application. If this problem persists, contact the after-sales service.</p>
51	<p>Watchdog overflow</p> <p>Warning or error according to the selection made in the configuration menu (module display) or in the configuration window (Zelio Soft 2 programming workshop).</p> <p>The cycle time in the module is too short compared with the application program execution time programmed in the controller.</p> <p>If the application requires a strict sampling of the module inputs/outputs, lengthen the cycle time in the module. To do this, configure the information either in the CONFIGURATION menu (module display) or in the configuration window (Zelio Soft 2 programming workshop).</p> <p>If the application does not require the cycle time, in CONFIGURATION select: No Action for the WATCHDOG.</p>
52	<p>The controller has executed an unknown operation</p> <p>If the fault is permanent, reload the firmware on the module and the user application. If this problem persists, contact the after-sales service.</p>
53	<p>Link between module and bus extension faulty</p> <p>Check operation of the extension (connection, power supply, fault).</p>
54	<p>Link between module and input/output extension faulty</p> <p>Check operation of the extension (connection, power supply, fault).</p>
58	<p>A fault is present in the firmware (software specific to the controller) or on a part of the controller hardware.</p> <p>If the fault is permanent, reload the firmware on the module and the user program. If this problem persists, contact the after-sales service.</p>

13. FAULT Menu

Number	Type of error
59	At the beginning of RUN on the module application: the application cannot switch to RUN as it is incompatible with the module physically connected to the supply. If this problem occurs, contact the after-sales service.
60	At the beginning of RUN on the module application: program incompatible with the bus extension physically connected to the supply. If this problem occurs, contact the after-sales service.
61	At the beginning of RUN on the module application: program incompatible with the Input/Output extension physically connected to the supply. If this problem occurs, contact the after-sales service.
62	Version (or release number) incompatibility when loading a program from the backup memory If this problem occurs, contact the after-sales service.
63	Hardware configuration incompatibility when loading a program from the backup memory If this problem occurs, contact the after-sales service.

Chapter 3 - Contents

Configuration Menu

1. PASSWORD Menu	37
2. FILTER Menu	40
3. Zx KEYS Menu	41
4. CHANGE D/T Menu	43
5. CHANGE SUMM/WINT Menu	45
6. WATCHDOG CYCLE Menu	46

1. PASSWORD Menu

Description

If the program is password-protected, (key displayed), the user must enter the password for certain operations.

The password protects access to the following menus:

- ◆ PROGRAMMING (LD STOP mode),
- ◆ MONITORING (LD RUN mode),
- ◆ PARAMETER,
- ◆ CONFIGURATION (STOP mode),
- ◆ CLEAR PROGRAM. (LD STOP mode),
- ◆ MODULE > MEM TRANSFER (STOP mode).

Note: It is possible to quit the screen without entering the password by using a combination of the Shift key (white key) and the Menu/Ok key (blue key).

Note: To return to the main menu from the CONFIGURATION menu, use the navigation key ←.

Entering the Password

Initially, the key is not displayed and each digit is replaced by a ?.

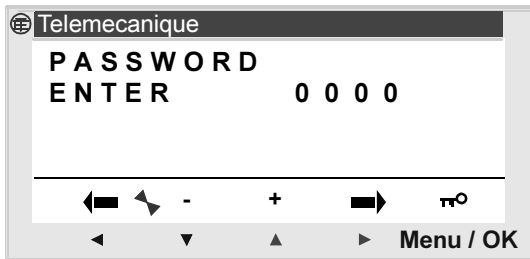

The message **ENTER** appears in the window.

Note: From this point, the key icon is displayed.

1. PASSWORD Menu

Entering procedure:

Steps	Description
1	Press →, the ? symbols are replaced by 0s (the 0 furthest to the left blinks).
2	Select the digit to enter using the arrow keys: ←→.
3	Select the value of the digit with the + and - keys in the contextual menu.
4	Validate the password with the Menu/OK key, which opens the validation window.
5	Confirm again with the Menu / OK key. Result: the display returns to the MAIN menu.

Deleting the password

To cancel the password, follow the same procedure used to enter it.

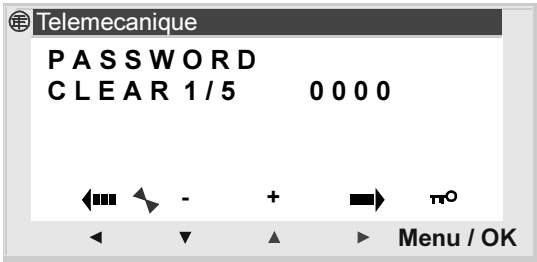

Initially, the key is displayed, meaning: module is password protected.

The message **CLEAR** and the number of attempts **1 / 5** appear in the window.

The following cases can occur:

- ◆ **Password is correct:** the password is then inhibited, and the module returns to the PASSWORD menu,
- ◆ **Password is incorrect:** the **CLEAR** counter is incremented.

1. PASSWORD Menu

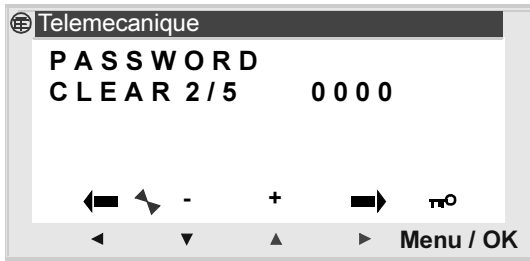

If an incorrect password is entered **5** times consecutively, the security function is locked for 30 minutes.

During this period, if the power supply to the module is cut off, the downcount will start again on power up.

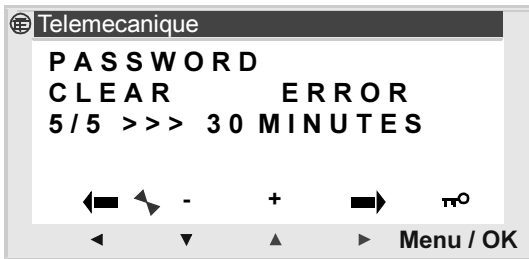

Modifying the password

To change the password, simply cancel the former one and enter a new one.

2. FILTER Menu

Description

This function allows faster detection of changes in states on all Discrete inputs.

Two choices are available:

- ◆ Fast,
- ◆ Slow.

Response time :

Filtering	Switching	Response time
Slow	ON→ OFF	5 ms
	OFF→ ON	3 ms
Fast	ON→ OFF	0.5 ms
	OFF→ ON	0.3 ms

This choice can only be made when the smart relay is set to STOP.

Note: By default, smart relays are configured to run in SLOW mode.

Note: This function is available on smart relays with a direct voltage power supply.

Note: To return to the main menu from the CONFIGURATION menu, use the navigation key ←.

Filter type selection

The current type is shown by the selection symbol (black lozenge).
Language selection procedure:

Steps	Description
1	Select the filter type: ↓↑ (the selection flashes).
2	Confirm with Menu / OK . Result: the display returns to the MAIN menu.

3. ZX KEYS Menu

Description

Note: Only accessible in LD mode.

The **Zx=KEYS** option lets the user enable or disable the use of arrow keys as pushbuttons.

Depending on the state of this option, the following functions are obtained:

- ◆ **Inactive:** the keys are only available for setting up parameters, configuring and programming the smart relay.
- ◆ **Active:** it is also possible to use them in a Ladder diagram.

In this configuration, they operate as pushbuttons: **Zx keys**, without requiring a terminal block input contact.

Note: To return to the main menu from the CONFIGURATION menu, use the navigation key ←.

Zx keys in RUN mode

By default, the Z keys are used as navigation keys.

In RUN mode, when the INPUTS-OUTPUTS screen, TEXT screen or DISPLAY screen is active, the number of the Z keys used in the program are displayed in the contextual menu line.

To activate the key, simply select the required key ← ↑ ↓ →.

Note: The number of the keys used in the program are displayed.

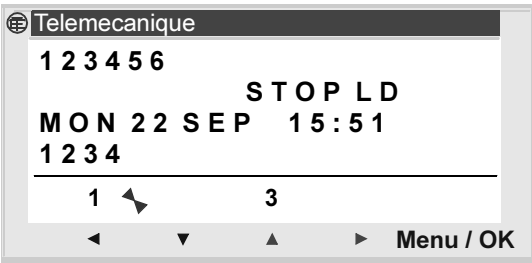

3. ZX KEYS Menu

Once enabled, the display returns to the MAIN menu.

Note: The function is inactive in PARAMETERS, MONITORING mode and in all of the function block parameter screens and configuration screens.

4. CHANGE D/T Menu

Description

This function is used to configure the date and time for the modules with a clock.

Illustration

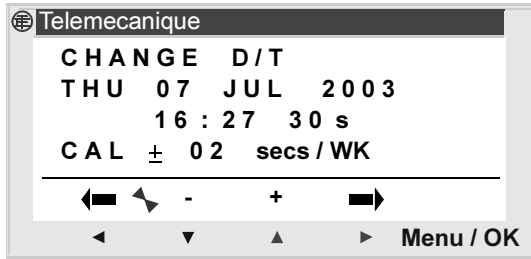

The modifiable parameters are:

- ◆ The day / week / month / year,
- ◆ The time,
- ◆ Minutes, the values being saved by pressing the Menu/Ok key; if you wish to specify the time more, you should complete the entry of modifications with minutes and seconds.
- ◆ Seconds,
- ◆ CAL: relay internal clock calibration in seconds per week.

The quartz crystal that controls the relay's real-time clock has a monthly drift that varies according to the relay's environmental conditions.

The maximum value for this drift is approximately one minute per month.

To estimate this drift, proceed by observing the drift on the module clock with respect to a standard reference clock for a few weeks or more.

4. CHANGE D/T Menu

Example:

If the user would like to reduce this drift, s/he can for example, make a correction of - 15 seconds per week to compensate for a drift of + 60 seconds. This compensation is executed on Sunday at one O'clock in the morning.

Note: This correction serves no purpose if the module is subject to long power interruptions or major variations in temperature.

Note: To return to the main menu from the CONFIGURATION menu, use the navigation key ←.

Configuring the clock

Procedure:

Steps	Description
1	Select the parameter to modify using the ← and → navigation keys. Result: the selected parameter flashes. (When you enter this mode, the day value is selected)
2	Modify the value of the parameter. The + and - keys of the contextual menu can be used to change the current value.
3	Validate the modifications by pressing Menu/OK . Result: the display returns to the MAIN menu.

Note: Zelio Logic contains a software module that determines the day of the week when the user selects the day of the month in the year.

5. CHANGE SUMM/WINT Menu

Description

This function is used to automatically change the time range: summer/winter, for the relays with a clock.

Illustration

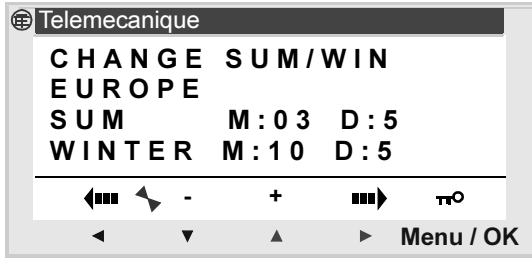

The following operating modes are possible:

- ◆ **NON**: no change,
- ◆ **Automatic**: the change takes place automatically, the dates are preset according to the geographic zone: (EUROPE: Europe, GB: Great Britain, USA),
- ◆ **OTHER ZONE**: (MANUAL) the change is automatic, but you must specify the month: **M** and the Sunday: **S** (1, 2, 3, 4 or 5) on which the summer/winter change takes place.

Note: To return to the main menu from the CONFIGURATION menu, use the navigation key ←.

Configuring the time change

Steps	Description
1	Select the parameter to modify using the ← and → navigation keys. Result: the selected parameter flashes.
2	Modify the value of the parameter. The + and - keys of the contextual menu are used to change the current value.
3	Confirm the modifications by pressing the Menu/OK key. Result: the display returns to the MAIN menu.

6. WATCHDOG CYCLE Menu

Description

The program execution time depends on the type and number of inputs-outputs and the number of extensions.

The value of the default execution cycle is 10 milliseconds.

Illustration

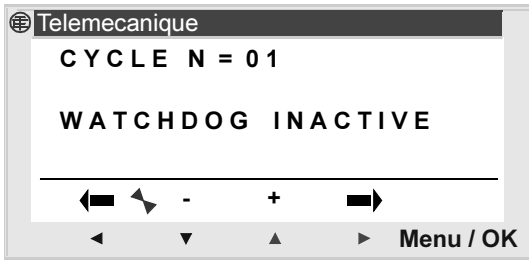

If the duration of the execution cycle of the program and the embedded software functions exceeds the cycle value selected by the programmer (N times 10ms), the WATCHDOG can be used to operate a specific action.

Note: To return to the main menu from the CONFIGURATION menu, use the navigation key ←.

Actions

The possible actions for the watchdog are:

- ◆ **INACTIF**: normal operating mode,
- ◆ **ALARME**: a warning state is positioned and the warning number corresponding to Cycle time overflow is accessible in the **FAULT** menu,
- ◆ **ERREUR**: the program stops (STOP mode) and the error number corresponding to: **Cycle time overrun** is accessible in the **FAULT** menu.

Parameter

The **N** adjustment parameter can have a value between 1 and 9; this parameter corresponds to :

WATCHDOG duration= N x 10 milliseconds

The N times adjustment is made according to the shortest input sampling period.

6. WATCHDOG CYCLE Menu

Configuring the watchdog

Procedure:

Steps	Description
1	Configure the CYCLE parameter using the + and - keys of the contextual menu.
2	Validate the line using one of the keys: ←→. Result: the CYCLE parameter is validated and the WATCHDOG parameter is activated: it blinks.
3	Configure the WATCHDOG parameter using the + and - keys of the contextual menu.
4	Validate the modifications by pressing Menu/OK . Result: the display returns to the MAIN menu.

Chapter 4 - Contents

Ladder Diagrams

1. Introduction	49
2. Discrete Inputs	50
3. Discrete Outputs	51
4. Auxiliary Relays	54
5. Arrow Keys	55
6. Clock Function Block	56
7. Counter Function Block	60
8. Counter Comparator Function Block	66
9. Fast Counter Function Block	67
10. Timer Function Block	74
11. Analog Comparator Function Block	83
12. Summer/Winter Time Change Function Block	87
13. LCD Screen Back-Light Function Block	88
14. Text Function Block	89
15. Modbus Inputs-Outputs	91

1. Introduction

An application can only be created from the front panel of the module in LD programming mode.

This Section details all possible elements in a Ladder diagram in LD mode that are recognized and used by the smart relays.

To better understand the functions performed by each element, where necessary a directly usable example is included.

The smart relays accept 120-line diagrams.

Note: Each line comprises a maximum of five contacts and must always include a coil. When the application requires more than five contacts to activate an action, the auxiliary relays can be used.

Ladder diagram example:

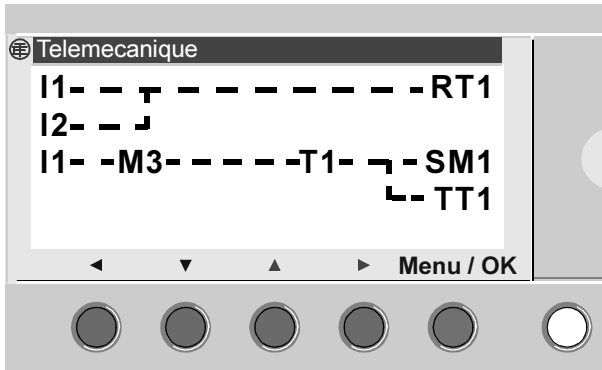

2. Discrete Inputs

A discrete input can only be used as a contact.

Representation	Function	No. on terminals	Description
I No.	Normally open	1 to R (II , IM , IO excluded) according to the module	The physical input to the smart relay. This contact gives the state of the sensor (switch, detector, etc.) connected to the corresponding input.
i No.	Normally closed		

Example 1:

I1 ————— **[Q1**

When input **I1** contact is closed, output **Q1** is activated.

Example 2:

i1 ————— **[Q1**

When input **I1** contact is open, output **Q1** is activated.

Note: **When analog inputs Ib and Ic are entered as contacts, they automatically operate as discrete inputs.**

3. Discrete Outputs

A discrete output can be used either as a coil or a contact.

Used as a coil

Usage mode	No. on the block	Description
\lceil QNo.	1 to G depending on smart relay	The coil is energized if the contacts that it is connected to are closed; otherwise it is not energized.
\lceil QNo.		Pulse supply, the coil is energized by a change of state. This is the same as an alternating control relay.
S QNo°		Coil " Set ", also called a latch or triggered coil. This coil is energized as soon as the contacts that are connected to it are closed. It remains triggered even if the contacts are no longer closed.
R QNo.		Coil " Reset ", also called an unlatch or release coil. This coil is disabled when the contacts that are connected to it are closed. It remains idle even if the contacts are no longer closed.

Used as a contact

Representation	Function	No. on the block	Description
QNo.	Normally open	1 to G depending on smart relay	The physical output from the smart relay.
qNo.	Normally closed		An output can be used as a contact to determine its state at a given time.

Example 1:

$Q1$ ————— \lceil $Q2$

When output $Q1$ is activated, output $Q2$ is also activated.

Example 2:

$q1$ ————— \lceil $Q2$

When output $Q1$ is disabled, output $Q2$ is activated. Output $Q2$ will always take the reverse state to output $Q1$.

3. Discrete Outputs

Note: The \int and \lfloor , SET and RESET functions must be used once and once only for each coil in a control diagram.

If a SET coil is used, we recommend you perform a RESET action for this coil.

The use of a SET coil on its own is only justified for triggering an alarm signal that can only be reset by an INIT+RESET program command.

Example - Using a remote (alternating) control relay

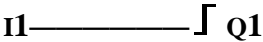

This is a very handy function that allows you to switch a light on or off using a pushbutton. If a pushbutton is connected to input **I1** and a light to output **Q1**, then each time the button is pressed, the light will come on if it was off or it will go off if it was on. To set up a two-way switch, simply connect the inputs in parallel and connect a pushbutton to each input.

Example - Using Set (Latch) and Reset (Unlatch) coils

To control the power supply to a device using a pushbutton to cut off the power supply to the same device. The following solution is applied

Electrical diagram	Smart relay solution

Pushbutton PB2 is connected to the smart relay, to input I2 and pushbutton PB3 to input I3. The device to control, in this case a light bulb called L1 is connected to output Q2.
 Pressing pushbutton PB2 will light the bulb.
 Pressing pushbutton PB3 will extinguish the bulb.

Note: The RESET order takes priority over the SET order.

3. Discrete Outputs

Latching

By default, after a cut in supply, the state of the outputs is that which corresponds to initialization of the program.

To restore the state of the outputs saved at the time of the power cut, activate the latching of the outputs in the parameters window by validating the parameter  .

4. Auxiliary relays

The auxiliary relays, **M** in the notation used, operate just like the output coils **Q**. The only difference is that they do not have any connection terminals.

There are 31 auxiliary relays (numbered in hexadecimal notation from 1 to 9 and from A to Y, though not using letters I, M and O).

They are used to save or forward a state. The saved state will then be used as the assigned contact.

Example - Using an auxiliary relay

Using two auxiliary relays to save the position of a number of inputs. These relays are then used to control a coil.

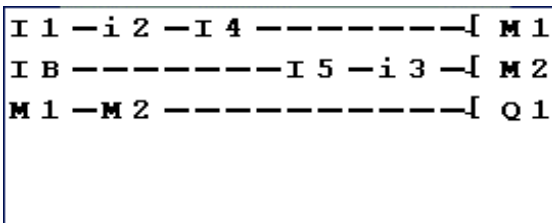

This type of Ladder diagram is often used to control the various states of a device.

Initialization

State of the contacts on initializing the program:

- ◆ Normally-open mode (direct state) is inactive,
- ◆ Normally-closed mode (reverse state) is active.

Latching

By default, after a cut in supply, the relay is that which corresponds to initialization of the program.

To restore the state of the relay saved at the time of the power cut, activate the latching of the relay in the parameters window by validating the parameter **↗**.

5. Arrow Keys

The arrow keys work just like the physical inputs **I**. The only difference is that they do not have any connection terminals.

They are used as pushbuttons.

They can only be used as contacts:

Representation	Function	No. on the relay	Description
ZNo.	Normally open	1 to 4	Representation of the arrow keys on the smart relay. This contact gives the state of the corresponding key. Z1 to Z4 from left to right
zNo.	Normally closed		

Note: So that the arrow keys may be used in this way, first check that they are activated in the **Zx=KEYS** function in the **CONFIGURATION** menu. The number of the keys is then displayed in the contextual menu at the bottom of the screen.

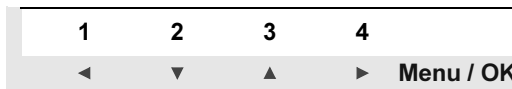

If not, when the smart relay is in RUN mode, these keys are only used to move within the menus.

Example of using the "up arrow" key

This example shows how to set up a remote (alternating) control relay that will work using key **Z1** and output **Q1**.

Z1 ————— **Q1**

Output **Q1** changes state each time you press



6. Clock Function Block

The Clock function block is used to validate time slots during which actions can be performed. It acts just like a programmable weekly timer and has four operating ranges (A, B, C, D) used to control its output.



Function block parameter setting can be accessed

- ◆ When entering a Ladder diagram line,
- ◆ From the **PARAMETER** menu if the block has not been padlocked.

The clock activation is **weekly**, and simply needs to be configured:

- ◆ Days of the week,
- ◆ Activation time range, by setting the start time: **ON** and the end time: **OFF**.

Used as a contact

Representation	Function	No.	Description
 No.	Normally open	1 to 8	The contact is closed when the Clock is in an enabled period.
 No.	Normally closed		The contact is closed when the Clock is not in an enabled period.

6. Clock function block

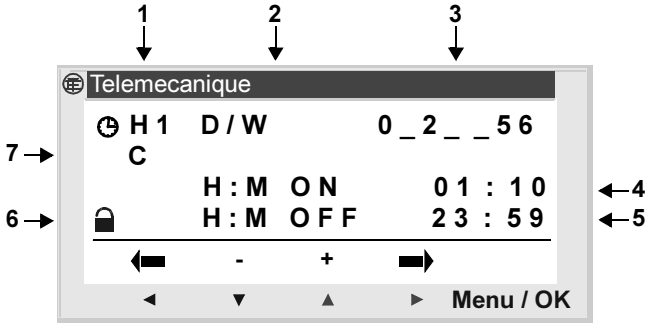

Clock function block parameters

Configuration parameter screen: D / W (day / week).



Parameter		Description
Clock module number	1	Eight blocks can be used, numbered from 1 to 8.
Type of date configuration	2	D/W: Days of the Week,
Validity day (D/W type)	3	Validity day: ♦ 0: Monday, ♦ 1: Tuesday, ♦ ... ♦ 6: Sunday. Days that are not selected are indicated by a _ character.

6. Clock function block

Parameter		Description
Start time (D/W type)	4	This is the operation start time, in Hour: Minute format (00.00 to 23.59).
End time (D/W type)	5	This is the operation end time, in Hour: Minute format (00.00 to 23.59).
Parameter lock  Locked  Unlocked	6	This parameter is used to lock the parameters of the Clock function block. Once locked, the preset value is no longer displayed in the PARAMETER menu.
Operating ranges	7	4 operating ranges are available: A, B, C, D.

6. Clock function block

Example - Time management using a Clock function block

To control a device from Monday to Saturday during two time slots: from 09.00 to 13.00 and from 15.00 to 19.00. The device is connected to the output **Q2** of the smart relay, using Clock block number 1.

The Ladder diagram control line is as follows:

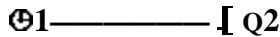

When **C1** is entered, the user must specify the operating ranges.

Note: The following keys are used: Menu/OK to select or validate a parameter, Z2 and Z3 to change the value of the selected parameter, Z1 and Z4 to move from one parameter to another.

Screen	Comments
	<p>First slot A: Monday to Saturday from 09.00 to 13.00. Now you must enter the second slot.</p>
	<p>Second slot B: Monday to Saturday from 15.00 to 19.00.</p>

Note: The example described in Chapter 7 describes another way of using time slots. It is possible to mix the two in order to resolve complex cases.

7. Counter Function Block

The Counter function block is used to up or down count pulses. The Counter function can be reset to zero or to the preset value (depending on the chosen parameter) during use.

It can be used as a contact to find out if:

- ◆ The preset value has been reached (upcounting),
- ◆ The value 0 has been reached (downcounting).

Function block parameter setting can be accessed

- ◆ When entering a Ladder diagram line,
- ◆ From the **PARAMETER** menu if the block has not been padlocked.

Used as a contact

When used as a contact, the counter indicates that the preset value and the current value are equal:

- ◆ The current value of the counter has reached the preset value (**TO** mode),
- ◆ The current value of the counter is equal to 0 (**FROM** mode).

Representation	Function	No.	Description
CNo.	Normally open	1 to G	The contact is closed when the counter reaches the preset value.
cNo.	Normally closed		The contact is closed until the counter has reached the preset value.







7. Counter Function Block

Used as a coil

Element	Description/Use	Example
CC	<p>Counting pulse input This element represents the block's counter input. Each time the coil is triggered, the counter increments or decrements by 1, depending on the chosen counting direction.</p>	<p>Application example : upcounting on the input to the Counter No.1 function block. I1————— CC1</p>
RC	<p>Reset initial counter state input This input resets the counter function to its initial state.</p> <ul style="list-style-type: none"> ◆ The current counting value is reset to zero if the counting type is TO, ◆ The current value is reset to the preset value if the counting type is FROM. 	<p>Application example : Resets Counter No.1 when the Up Arrow key is pressed on the arrow keypad : Z1————— RC1</p>
DC	<p>Counting direction input This element represents the counter input that determines the direction of counting. If this coil is triggered, the function block downcounts, if not the function block counts. By default (this input is not wired) the function block counts.</p>	<p>Application example : up or downcounting, depending on the status of a smart relay input. I2————— DC1</p>

7. Counter Function Block

Parameterization

Element	Description/Use	Example
T	Type of counting. This parameter can be used to select the operating mode of the counter: <ul style="list-style-type: none"> ◆ TO: upcount towards the preset value. ◆ FROM: downcount from the preset value. 	
P	Preset value. This value is between 0 and 32767, and represents: <ul style="list-style-type: none"> ◆ The value to reach in mode: upcount towards the preset value (TO mode). ◆ The initial value in mode: downcount from the preset value (FROM mode). 	
	This parameter is used to lock the Counter function block's preset value. Once locked, the preset value is no longer displayed in the PARAMETER menu.	 Locked  Unlocked
C or c	Used as a contact, this Counter function block element indicates that the preset value and the current value are equal.	Application example : Lighting an indicator light connected to smart relay output Q1 when the preset value is reached. Otherwise the indicator light is out. 
	This latching function can be used to save the state of the current timer values in the event of a power outage.	 Not activated  Activated

7. Counter Function Block

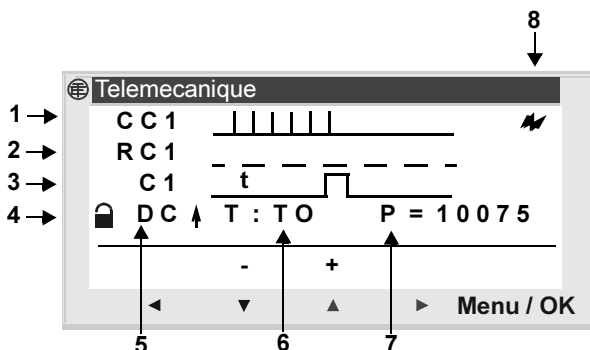

- 1 – Control input
- 2 – Reset input
- 3 – Counter output - when the preset is reached
- 4 – Parameter lock
- 5 – Counting direction
- 6 – Type of counting (TO: upcounting/FROM: downcounting)
- 7 – Value to reach - also called the preset value
- 8 – Latching

Example - Using a Counter function block

Screen	Description
<pre> I 1 ----- C C 1 I 2 ----- R C 1 </pre>	<p>Counting and Resetting : The counter is incremented each time input I1 is activated. The counter is reset each time input I2 is activated.</p>
<pre> I 1 ----- C C 1 L D C 1 I 2 ----- R C 1 </pre>	<p>Counting and Resetting : The counter is decremented each time input I1 is activated. The counter is reset each time input I2 is activated.</p>

7. Counter Function Block

Screen	Description
	<p>Upcounting, downcounting and Resetting : The counter is incremented each time input I1 is activated.</p> <p>The counter is decremented each time input I3 is activated.</p> <p>The counter is reset each time input I2 is activated.</p>

Current Counter Value

This is the value at any given instant resulting from the successive up/down counting actions that have occurred since the last time the counter was reset to its initial state.

This value is between [0...32767]. Once these values have been reached, the current value remains at 0 (after downcounting) or + 32767 (after upcounting).

Initialization

State of the contacts and the current value on initialization:

- ◆ Normally-open mode (direct state) is inactive,
- ◆ Normally-closed mode (reverse state) is active,
- ◆ The current value is zero.

Latching

By default, after a cut in supply, the counter is in the state that corresponds to initialization of the program.

To restore the state of the counter saved at the time of the power cut, activate the latching of the counter in the parameters window by validating the parameter  .

7. Counter Function Block

Upcounting Function: TO

The following diagram shows the operation of the counter in TO mode: upcounting to the preset value.

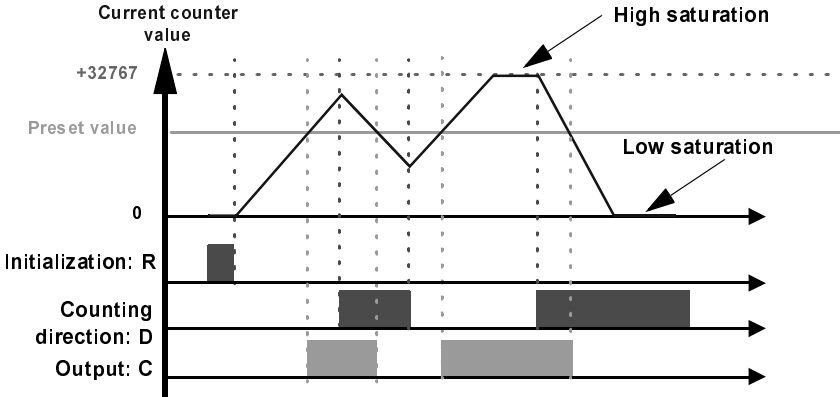

Downcounting Function: FROM

The following diagram shows the operation of the counter in FROM mode: downcounting from the preset value.

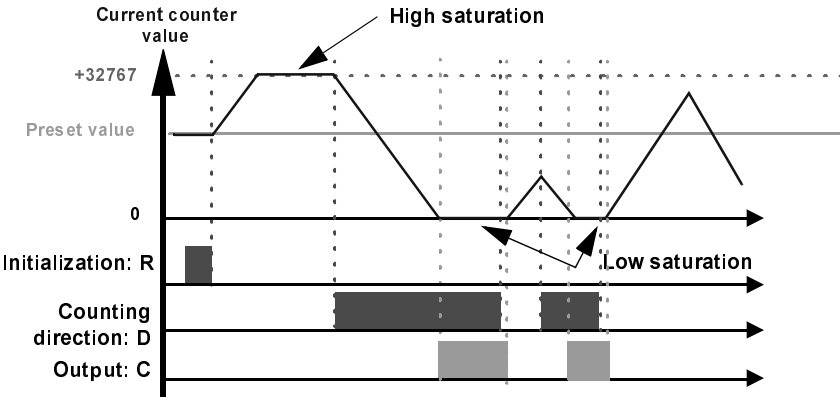

8. Counter comparator function block

Description

This function is used to compare the current counting values of one or two counters with a value.

Note: The counter comparator can only be programmed using the programming workshop (refer to the Zelio Soft 2 on-line help manual for further information).

Used as a contact

Representation	Function	No.	Description
VNo.	Normally open	1	The contact is closed when the comparison formula is checked.
vNo.	Normally closed		

Comparison parameters

The comparison formula is as follows:

Offset x + Value1 <Comparison operator> Offset Y + Value2

The different parameters are as follows:

- ◆ **Offset X and Offset Y:** these are constants between: -32768 and 32767,
- ◆ **Value1 and value2:** represent the counters to compare. The selection is made using the scroll menu.

The comparison operators you can choose from the **Parameters** window are:

Zelio	Description	Symbol	Description
>	Greater than.	≠	Different to.
≥	Greater than or equal to.	≤	Less than or equal to.
=	Equal to.	<	Less than.

The **lock front panel** option is used to lock the function: when locked, the preset value no longer appears as a modifiable parameter.

9. Fast counter function block

Description

The Fast Counter function enables you to count pulses up to a frequency of 1 kHz.

Use as a **K1** contact, to find out if:

- ◆ The preset value has been reached (upcounting),
- ◆ The value 0 has been reached (downcounting).

The fast counter inputs are implicitly connected to the **I1** and **I2** module inputs:

- ◆ A pulse (rising edge) on the **I1** input increments the counter,
- ◆ A pulse (rising edge) on the **I2** input decrements the counter.

These should not be used on the wiring sheet.

The Fast counter function can be reset to zero by using **RK1** or to the preset value (depending on the chosen parameter) during use, with the reset input.

The counter only operates if the **TK1** enable function input is active.

Repetitive mode can be used with a time-delay value.

Note: If the current value of the counter exceeds the upper limit: +32767, it goes to -32768.

If the current value of the counter exceeds the lower limit: -32767, it goes to +32768.

Used as a contact

When used as a **K** contact, the counter indicates that the preset value and the current value are equal (counting threshold reached):

- ◆ The current value of the counter has reached the preset value (**TO** mode),
- ◆ The current value of the counter is equal to 0 (**FROM** mode).

9. Fast counter function block

Representation	Function	No.	Description
K1	Normally open	1	The contact is closed when the counter reaches the preset value.
k1	Normally closed		The contact is closed until the counter has reached the preset value.





Used as a coil

Element	Description/Use	Example
TK1	<p>Enable Function input This element enables the counter.</p>	<p>Application example : The activation of input I1 enables counting. I3 ————— TK1</p>
RK1	<p>Reset initial counter state input This input resets the counter function to its initial state.</p> <ul style="list-style-type: none"> ◆ The current counting value is reset to zero if the counting type is TO, ◆ The current value is reset to the preset value if the counting type is FROM. 	<p>Application example : Counter reset on pressing the Up arrow key on the arrow keypad : Z1 ————— RK1</p>

Parameter setting

Element	Description/Use
Cycle type	<p>Type of cycle counting:</p> <ul style="list-style-type: none"> ◆ Single, ◆ Repetitive: in this case parameter I (pulse duration) is displayed.

9. Fast counter function block

Element	Description/Use
<p style="text-align: center;">I</p>	<p>Duration of pulse This value must be between 1 and 32767 (x 100ms). This parameter is only displayed if the cycle is repetitive.</p>
<p style="text-align: center;">P</p>	<p>Preset value. This value is between 0 and 32767, and represents:</p> <ul style="list-style-type: none"> ◆ The value to reach in mode: upcount towards the preset value (TO mode). ◆ The initial value in mode: downcount from the preset value (FROM mode).
<p style="text-align: center;">T</p>	<p>Type of counting. This parameter can be used to select the operating mode of the counter:</p> <ul style="list-style-type: none"> ◆ TO: upcount towards the preset value. ◆ FROM: downcount from the preset value.
<p>  Locked  Unlocked </p>	<p>This parameter is used to lock the Counter function block's preset value. Once locked, the preset value is no longer displayed in the PARAMETER menu.</p>
<p>  Not activated  Activated </p>	<p>This latching function can be used to save the state of the current timer values in the event of a power outage.</p>

9. Fast counter function block

Illustration: parameter screen for a fast counter in Zelio entry / Front panel mode

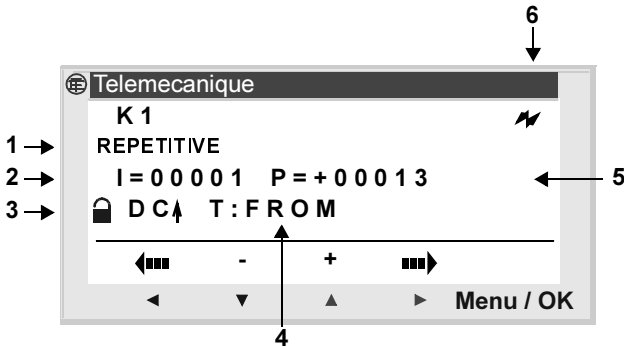

- 1 – Type of cycle
- 2 – Duration of pulse
- 3 – Parameter lock
- 4 – Type of counting
- 5 – Preset value
- 6 – Latching

Current fast counter value

This is the value at any given instant resulting from the successive up/down counting actions that have occurred since the last time the counter was reset to its initial state.

If the current value of the counter exceeds the upper limit: +32767, it goes to -32768.

If the current value of the counter exceeds the lower limit: -32767, it goes to +32768.

Initialization

State of the contacts and the current value on initialization:

- ◆ Normally-open mode (direct state) is inactive,
- ◆ Normally-closed mode (reverse state) is active,
- ◆ The current value is zero.

9. Fast counter function block

Latching

By default, after a cut in supply, the counter is in the state that corresponds to initialization of the program.
To restore the state of the counter saved at the time of the power cut, activate the latching of the counter in the parameters window by validating the parameter.

Up-Counting Function in Single Cycle Mode

The following diagram shows the operation of the counter with initialization at 0:

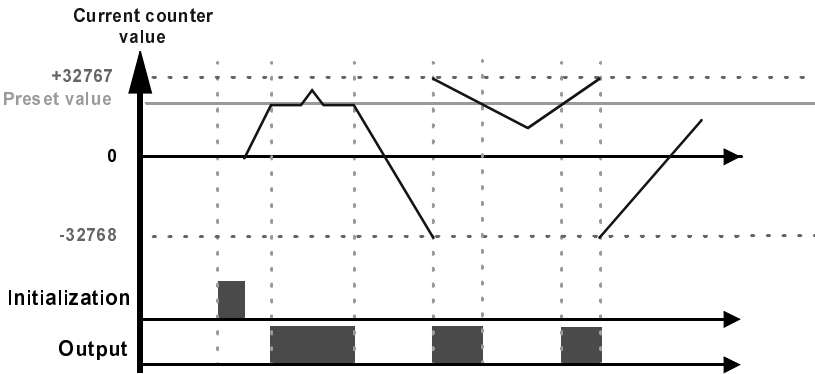

Down-Counting Function in Single Cycle Mode

The following diagram shows the operation of the down-counter with initialization at the preset value :

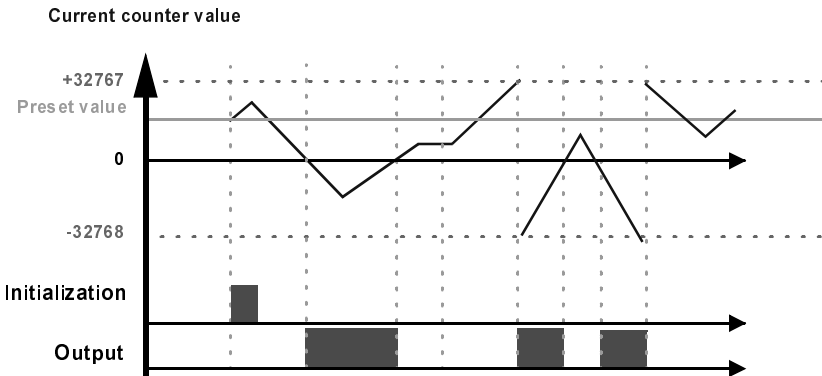

9. Fast counter function block

Up-Counting Function in Repetitive Cycle Mode

The following diagram shows the operation of the counter with forcing to 0 of the current value on initialization, or when the count value has reached the preset value:

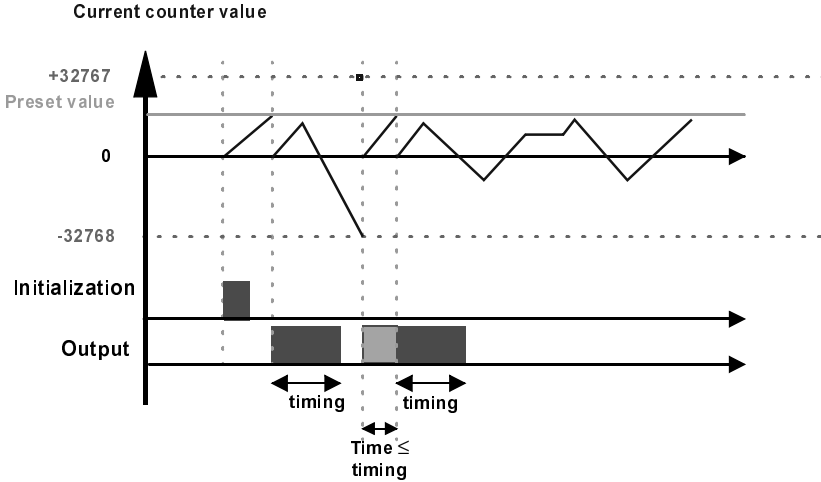

The output switches to the **Inactive** state when the predefined pulse duration value has run out. If the switch condition is Active before the switch to the Inactive state, the output pulse is prolonged by the DURATION OF THE PULSE (Timing).

9. Fast counter function block

Down-Counting Function in Repetitive Cycle Mode

The following diagram shows the operation of the down-counter with forcing to the preset value of the current value on initialization, or when the count value has reached 0:

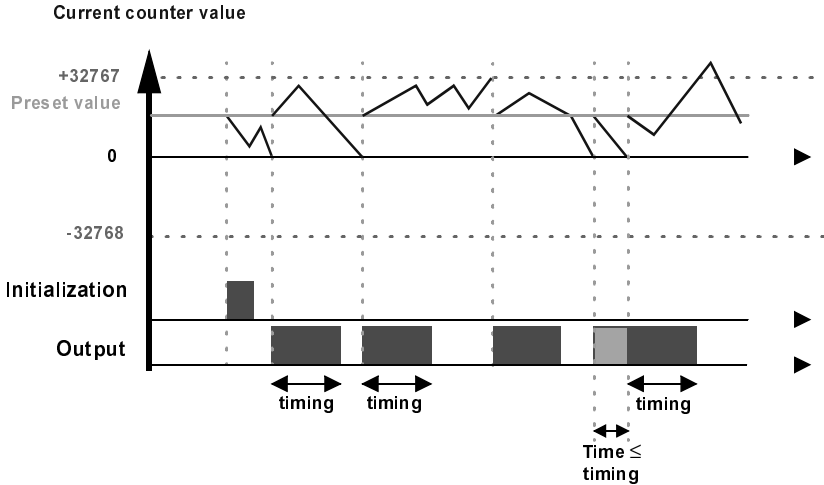

The output switches to the **Inactive** state when the predefined pulse duration value has run out. If the switch condition is Active before the switch to the Inactive state, the output pulse is prolonged by the DURATION OF THE PULSE (Timing).

10. Timer Function Block

The Timer function block is used to delay, prolong and control actions during a set period of time. It has a reset input, a command input and an output used to indicate timer time-out.

Function block parameter setting can be accessed :

- ◆ When entering a Ladder diagram line,
- ◆ From the **PARAMETER** menu if the block has not been padlocked.

Durations can be set using one or two preset values, according to the type of timer.

There are 11 types of timer (see details in the settings section).

Used as a contact

Representation	Function	No.	Description
T No.	Normally open	1 to G	The operation of this output contact depends on Timer parameter settings. The possible parameter settings are described in the remainder of this paragraph.
t No.	Normally closed		

10. Timer Function Block



Used as a coil

Element	Description/Use
TT	Used as a coil in a Ladder diagram, this element represents the Timer function block control input. Its operation depends on the type used. (See the following table for further details).
RT	Used as a coil in a Ladder diagram, this element represents the reset input. Triggering the coil will reset the current Timer value: The T contact is disabled and the block is ready for a new timer cycle.

Parameter setting

Element	Description/Use
Type	<p>There are ten types of Timer. Each type triggers a specific kind of operation used to handle all possible cases in an application.</p> <ul style="list-style-type: none">◆ A: operation with control held down,◆ a: operation with pulse start/stop,◆ C: idle,◆ A/C: combination of A and C timers,◆ B: pulse control activation switch: pulse calibrated on rising edge of the control input,◆ W: pulse control deactivation switch: pulse calibrated on the control input falling edge,◆ D: Symmetrical flashing,◆ d: flasher with pulse start/stop control: synchronous,◆ L: flasher with control held down: asynchronous,◆ I: Flasher with pulse start/stop control: asynchronous,◆ T: Total activity.
t=00.00 or A=00.00 B=00.00	<p>Value to reach. This value is also called the preset value. The effect of this value varies depending on the type used. Refer to the table on the next page for further details.</p> <p>For A/C and LI type timers, the parameter is replaced by the following parameters:</p> <ul style="list-style-type: none">◆ A: A/C latch delay.◆ B: A/C timer off-delay.

10. Timer Function Block

s	<p>Preset value time unit. There are five possible cases:</p> <ul style="list-style-type: none"> ◆ 1/100th of a second: 00.00 s (Maximum: 99.99) ◆ 1/10th of a second: 000.0 s (Maximum: 999.9) ◆ Minutes: seconds: 00:00 M:S (Maximum: 99 :59) ◆ Hours: minutes: 00 : 00 H:M (Maximum: 99 :59) ◆ Hours 0000 H (Maximum: 9999) <p>Only for type T (Total activity)</p>
	<p>This parameter is used to lock the Timer function block preset value. Once locked, the preset value is no longer displayed in the PARAMETER menu.</p>
T or t	<p>Used as a contact, this function block element represents the Timer output. Its operation depends on the type selected. (See the table on the next page).</p>
	<p>This function can be used to save the state of the current timer values in the event of a power outage.</p>

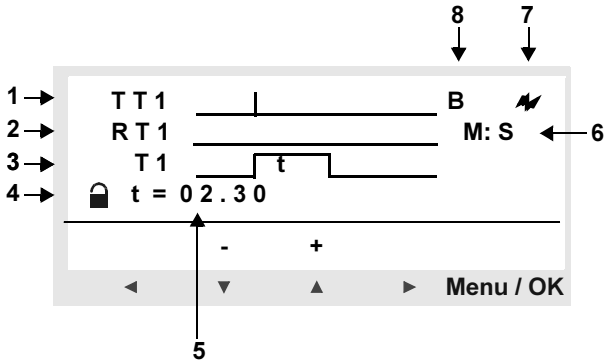

- 1 – Timer control input
- 2 – Timer reset input
- 3 – Timer output (or when the Preset time is reached)
- 4 – Parameter lock
- 5 – Preset time; for A/C and LI type timers, this parameter is replaced by parameters A: latch delay and B: unlatch delay.
- 6 – Preset time unit
- 7 – Latching
- 8 – Type of timer

10. Timer Function Block

Type of Timer

A: Operation with control held down

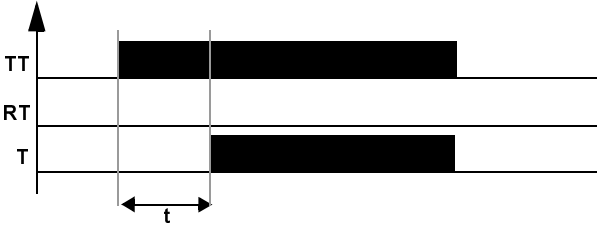

a: Operation with pulse start/stop

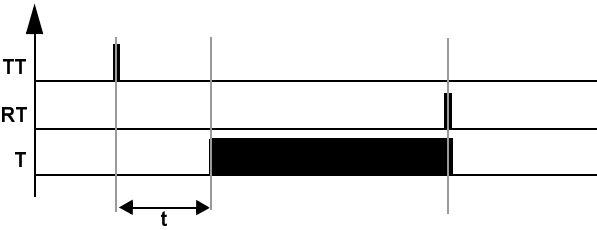

C: Idle

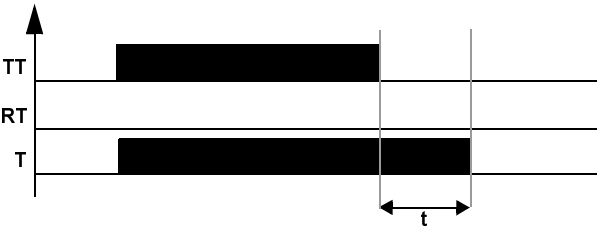

A/C: Combination of A and C timers

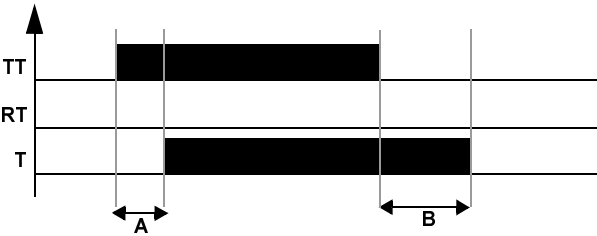

10. Timer Function Block

B: Pulse control activation switch: pulse calibrated on rising edge of the control input

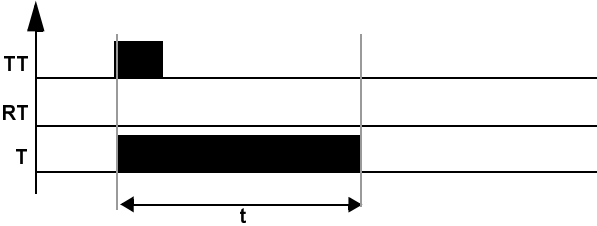

W: Pulse control deactivation

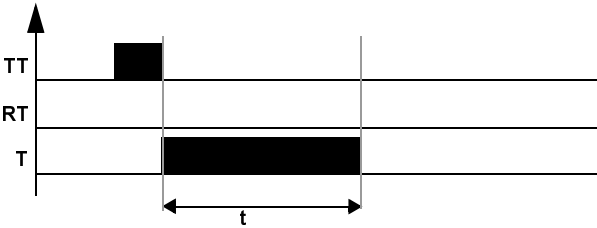

D: Flasher with control held down: symmetrical

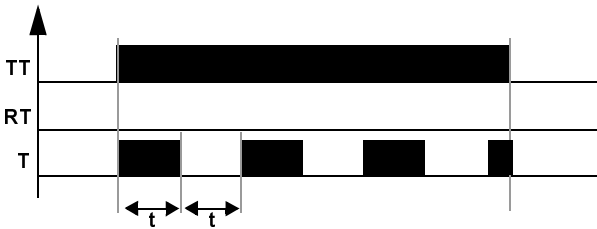

d: Flasher with pulse start/stop control: symmetrical

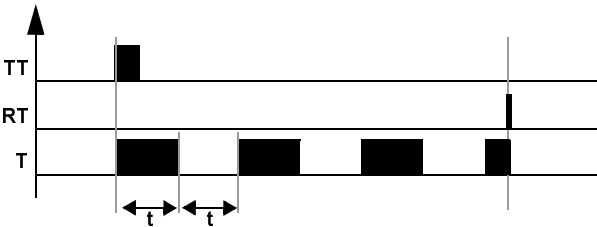

10. Timer Function Block

Li: Flasher with control held down: asymmetrical

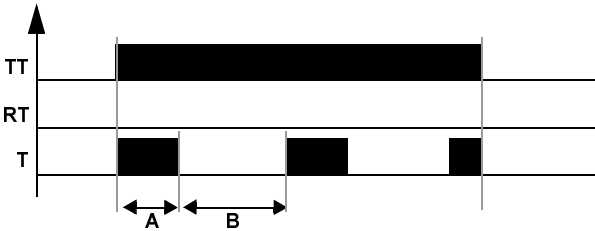

li: Asymmetrical Flasher Unit; Press to Start/Stop

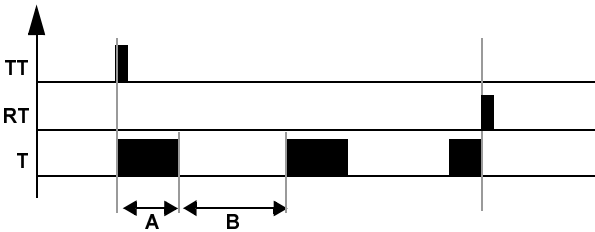

T: Total activity with Reset :

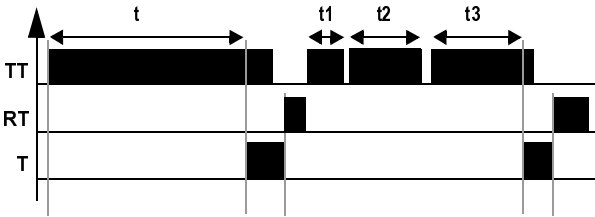

Total operation time: $t_1 + t_2 + t_3 = t$

For the total activity counter type, the preset value can be reached:

- ◆ In one step: t ,
- ◆ In several steps: $t_1 + t_2 + \dots + t_n$.

Initialization

State of the contacts and the current value on initialization:

- ◆ Normally-open mode (direct state) is inactive,
- ◆ Normally-closed mode (reverse state) is active,
- ◆ The current value(s) are reset to zero.

10. Timer Function Block

Example - Using a Timer function block

Implementing a stairway lighting timer:
 The pushbuttons on each floor are connected to smart relay input **I1**.
 The Timer No.1 function block set for a two minute and thirty second duration controls output **Q4**.
 Output **Q4** is connected to the lighting system.

The Ladder diagram control lines are as follows:

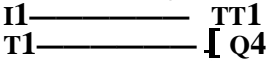

When entering **TT1** the Timer function block parameters must be set.

Note: The following keys are used: **Sel./OK** to select or validate a parameter, **Z2** and **Z3** to change the value of the selected parameter, **Z1** and **Z4** to move from one parameter to another.

Screen	Comments
	<p>This is the first screen. First select the type of Timer function block. (1 time arrow key → then 3 times arrow key ↑)</p>
	<p>Once the type of Timer function block is selected: type B, pulse calibrated. Now select the time base. (2 times → then 2 times ↑)</p>

10. Timer Function Block

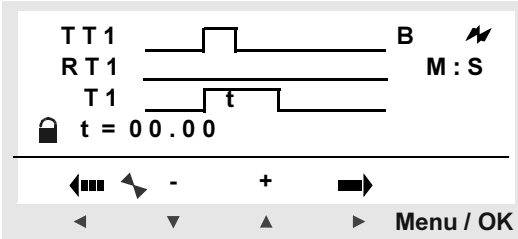
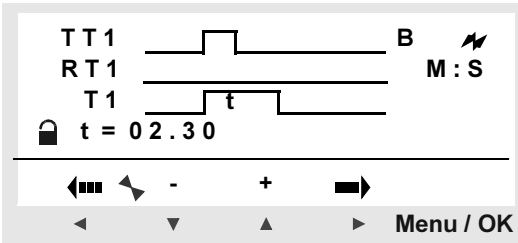
Screen	Comments
 <p>TT1 _____ B ⚡ RT1 _____ M : S T1 _____ t 🔒 t = 00.00</p> <p>◀ ◂ ◃ ▶ - + ▸</p> <p>◀ ▼ ▲ ▶ Menu / OK</p>	<p>Once the time base is selected M : S, enter the required duration. (2 times → then ↑)</p>
 <p>TT1 _____ B ⚡ RT1 _____ M : S T1 _____ t 🔒 t = 02.30</p> <p>◀ ◂ ◃ ▶ - + ▸</p> <p>◀ ▼ ▲ ▶ Menu / OK</p>	<p>Once the duration has been selected, parameter setting is complete. Press Menu/OK to return to Diagram Line entry (after validation).</p>

Note: To start the timer, do not forget to set the smart relay to **RUN**.

10. Timer Function Block

Behavior after a power break

If a power break occurs while a timer function block is running, any time already elapsed is lost.

When the supply voltage returns, the time function block is initialized for a new operating cycle.

If the application requires it, the time already elapsed can be saved before the power break occurs.

To restore the state of the counter saved at the time of the power cut, activate the latching of the timer in the parameters window by validating the parameter  .

Stopping the smart relay will initialize the timer function blocks.

11. Analog Comparator Function Block

Analog Comparator function blocks are used to compare a measured analog value with an internal reference value and also to compare two measured analog values.

The result obtained from this comparison is used in the form of a contact.

Analog automation functions can be used with smart relays equipped with a clock and supplied by DC.

The existence of these mixed Discrete / Analog inputs is characterized by the presence of Discrete inputs numbered from **IB** to **IG** (maximum configuration).

Analog Comparator function **A** is used to:

- ◆ Perform a comparison between a measured analog value and an internal reference value.
- ◆ Compare two measured analog values.
- ◆ Compare two measured analog values with hysteresis value.

The result obtained from this comparison is used in the form of a contact.

Note: The text block can only be programmed using the programming workshop (refer to the Zelio Soft 2 on-line help manual for further information).

Used as a contact

Representation	Function	No.	Description
A No.	Normally open	1 to G	The contact shows the position of a measured analog value in relation to a reference value or it represents a comparison between two measured analog values. It's value depends on the type of analog function block chosen and configured.
a No.	Normally closed		

Note: An analog function block is only used as a contact.

11. Analog Function Block

Parameter setting

Comparator parameter screen, hysteresis-type in Zelio entry / Front panel mode:

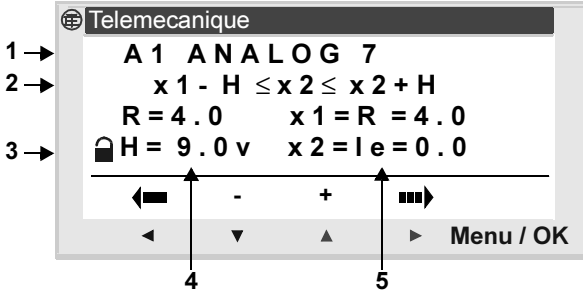

Simple comparison:

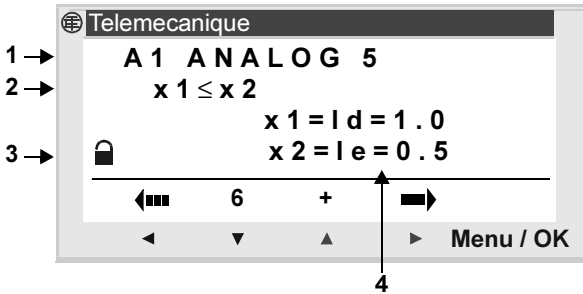

- 1 – Type of comparison
- 2 – Comparison formula
- 3 – Parameter lock
- 4 and 5 – Parameters of the comparison formula.

If this block is locked, the reference voltage or the hysteresis value (depending on the chosen type) no longer appears in the **PARAMETER** menu.

When the function block is unlocked, the admissible values are between 0 and 9.9 Volts.

Function block parameter setting can be accessed :

- ◆ When entering a Ladder diagram line,
- ◆ From the **PARAMETER** menu if the block has not been padlocked.

11. Analog Function Block

Types of comparators

The simple comparison formula is as follows:

$$\text{Value1} <\text{Comparison operator}> \text{Value2}$$

For a comparison with hysteresis:

$$\text{Value1} - H \leq \text{Value2} \leq \text{Value1} + H$$

In the following table x1 and x2 represent the analog inputs (or a Reference) to compare.

The possible values are: Reference, lb, lc, ld, le, lf and lg with x1 different to x2.

Block	Type of comparator	Description
1	$x1 > x2$	The contact is closed when the condition: $x1 > x2$ is checked
2	$x1 \geq x2$	The contact is closed when the condition: $x1 \geq x2$ is checked
3	$x1 = x2$	The contact is closed when the condition: $x1 = x2$ is checked
4	$x1 \neq x2$	The contact is closed when the condition: $x1 \neq x2$ is checked
5	$x1 \leq x2$	The contact is closed when the condition: $x1 \leq x2$ is checked
6	$x1 < x2$	The contact is closed when the condition: $x1 < x2$ is checked.
7	$x1-H \leq x2 \leq x1+H$	The contact is closed when the condition: $x1-H \leq x2 \leq x1+H$ is checked.(H represents the hysteresis parameter)

R: Reference and H: The Hysteresis parameter may have values between 0.0 and 9.9.

11. Analog Function Block

Initialization

State of the contacts on initializing the program:

- ◆ Normally-open mode (direct state) is inactive,
- ◆ Normally-closed mode (reverse state) is active.

Example - Using an analog function block

To control a heating element using smart relay output Q1 when the temperature level is below 20°C.

A temperature sensor is used, providing a 0-10 volt signal for a -10° to + 40°C temperature range.

A temperature of 20°C corresponds to a voltage level of 6 volts on the sensor.

Screen	Comments
<p>A1 —————] Q1</p>	Analog function block contact A1 is used to control output Q1.
<div style="border: 1px solid gray; padding: 5px;"> <p>A 1 ANALOG 5 $x 1 \leq x 2$ R = 6.0 $x 1 = I b$ $x 2 = R$</p> <hr/> <p style="text-align: center;"> - + </p> <p style="text-align: center;"> Menu / OK </p> </div>	Analog function block contact A1 is configured as follows: Ib =< Reference Reference voltage = 6.0 volts

12. Summer/winter time change function block

Description

The output of this function is at STOP throughout winter time, and switches to RUN throughout summer time.

By default, there is no summer/winter time change.

This function can be activated in the menu **CONFIGURATION/CHANGE SUMMER/WINTER**.

Note: This function is only available in relays containing a real-time clock.

If this option is validated, the changeover dates must be defined:

- ◆ Either using one of the predefined geographic zones,
- ◆ Or by manually configuring the date (month/Sunday).

Used as a contact

Representation	Function	No.	Description
W No.	Normally open	1	The contact is closed throughout summer time.
w No.	Normally closed		

Parameters

The following operating modes are possible:

- ◆ **No**: no change,
- ◆ Change is automatic, the dates are predefined according to the geographic zone (EUROPE: Europe, GB: Great Britain, USA),
- ◆ **OTHER ZONE**: the change is automatic, but you must specify the month: **M** and the Sunday: **S** (1, 2, 3, 4 or 5) of the changeover.

13. LCD screen back-light function block

Description

The screen back-light output is used to control the lighting of the LCD per program.

In STOP and RUN modes, the LCD screen is lit for 30 seconds when the user presses any of the buttons on the front panel.

Used as a coil

Representation	Function	No.	Description
LNo.	Normally open	1	The LCD is lit as long as the associated contact is active.

14. Text function block

Description

The **TEXT** automation function is used to display text or a numerical value (current value or preset value) on the LCD instead of the **INPUTS-OUTPUTS** screen.

A **TEXT** block can display a maximum of 4 lines, corresponding to a combination of:

- ◆ Text (one per line of LCD) of up to 18 characters,
- ◆ Numerical values (refer to the Zelio Soft 2 Text Block on-line help manual).

Up to 16 text blocks can be used (X1 to XG) simultaneously in one program, but only the last block to be activated is displayed.

Pressing the **Shift** and **Menu/OK** keys in order and simultaneously switches the display from the **TEXT** screen to the **INPUTS-OUTPUTS** screen.

Pressing the two keys again simultaneously returns the display to the **TEXT** screen.

Note: The text block can only be programmed using the programming workshop (refer to the Zelio Soft 2 on-line help manual for further information).

Used as a coil

Representation	Function	No.	Description
TX No.	Normally open	1	Display activated when the associated contact becomes active.
RX No.	Normally open	1	Display deactivated when the associated contact becomes active.

The information is displayed on the module if the contact connected to the **TX** text coil is active. It disappears if the corresponding **RX** is activated (return to **INPUTS-OUTPUTS** screen).

14. Text function block

Example - Using a Text function block

- I1 — TX1 -
- I2 — RX1 -

Activation of input I1 displays the text on the LCD. Activating input I2 makes the text disappear.

15. Modbus Inputs-Outputs

Description

A Modbus **SR3 MBU01BD** extension module may be added onto a basic Zelio 2 **SR3 BxxxBD** type module.

In **LD** mode, the application cannot access the four 16-bit data exchange words. Data transfer between master is implicit and completely transparent.

Note: The Modbus Zelio 2 module only operates in Modbus slave mode.

Parameters

Parameter setting can only be performed using the programming workshop (refer to the Zelio Soft 2 on-line help manual for further information).

Words to be sent to master

The words to be sent to the master are automatically written by duplicating the discrete I/Os as follows:

															Modbus Address(Hexa)		
IG	IF	IE	ID	IC	IB	IA	I9	I8	I7	I6	I5	I4	I3	I2	I1	0000	
0	0	0	0	0	0	0	0	IR	IQ	IP	IN	IL	IK	IJ	IH	0001	
0	0	0	0	0	0	QA	Q9	Q8	Q7	Q6	Q5	Q4	Q3	Q2	Q1	0002	
0	0	0	0	0	0	0	0	0	0	0	QG	QF	QE	QD	QC	QB	0003

Most significant byte Least significant byte

I1 to IG: discrete input states for the SR3 BxxxBD base.

IH to IR: discrete input states for the SR3 XTxxxBD extension.

Q1 to QA: discrete output states for the SR3 BxxxBD base.

QB to QG: discrete output states for the SR3 XTxxxBD extension.

15. Modbus Inputs-Outputs

Words sent by the master.

Words sent by the master are not processed by the Zelio 2 module (in LD mode).

The (Hexa) addresses for these four 16-bit words are as follows:
0010 / 0011 / 0012 / 0013.



Chapter 5 - Contents

Entering Ladder Diagrams

- 1. Rules for Entering Ladder Diagrams _____ 95
- 2. Element Entry Method _____ 97
- 3. Link Entry Method _____ 99
- 4. Automation Function Parameter Entry Method _____ 100
- 5. Deleting and Inserting Ladder Diagram Lines _____ 102

1. Rules for Entering Ladder Diagrams

Description

A smart relay lets you enter 120 line Ladder diagrams. The smart relay's display screen can be used to display these lines, four at a time, in the following way:

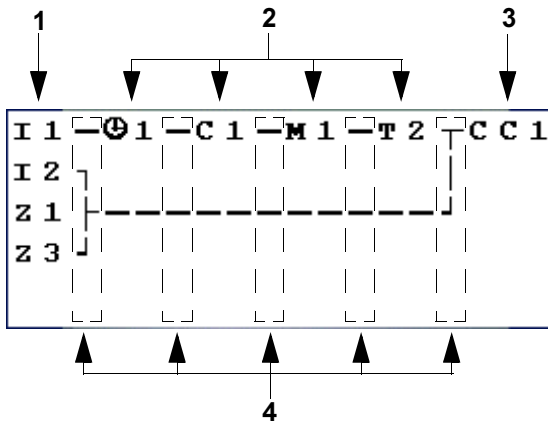

Description	
1	Column reserved for contacts (conditions).
2	Column reserved for contacts (conditions) and links.
3	Column reserved for coils (actions).
4	Column reserved for links.

Each line comprises five fields each with two characters reserved for contacts (conditions). The middle four columns can also be used to host links. The last three character column is reserved for coils (actions).

Links must be entered between the contact and coil columns.

A Ladder diagram is entered into the smart relay using the front panel keys.
(see the description of control keys in chapter 1 section 3).

1. Rules for Entering Ladder Diagrams

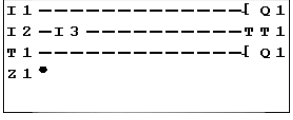
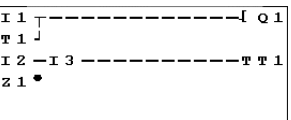
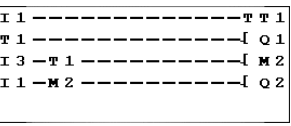
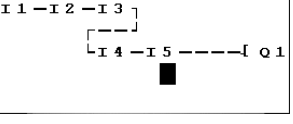
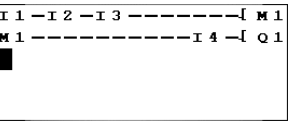
Rules	Incorrect	Correct
<p>Each coil must only be entered once in the right hand column</p>	 <pre> I 1 -----[Q 1 I 2 -I 3 -----T T 1 T 1 -----[Q 1 Z 1 • </pre>	 <pre> I 1 -----[Q 1 T 1] I 2 -I 3 -----T T 1 Z 1 • </pre>
<p>Contacts and coils can be entered as many times as necessary in the five left hand columns</p>		 <pre> I 1 -----T T 1 T 1 -----[Q 1 I 3 -T 1 -----[M 2 I 1 -M 2 -----[Q 2 </pre>
<p>Links must always run from left to right</p>	 <pre> I 1 -I 2 -I 3] [-----] [I 4 -I 5 -----[Q 1 </pre>	 <pre> I 1 -I 2 -I 3 -----[M 1 M 1 -----I 4 -[Q 1 </pre>
<p>If S (Set) (Latch) coils are used in a Ladder diagram</p>	<p>If no R (Reset) (Unlatch) coils are used, the corresponding coil will always be set to 1.</p>	<p>An R (Reset) (Unlatch) coil must be used for reset purposes.</p>

Note: Smart relays run programs from top to bottom and from left to right.

2. Element Entry Method

Entering an element

It is only possible to position an element (contact or coil) when the blinking ■ cursor is displayed on screen.

Contacts are entered in the five left hand columns and coils can only be entered in the last column.

Entering a contact

- 1- Place the blinking ■ cursor in the required position using keys **Z1** to **Z4**: ◀ ▼ ▲ ▶.
- 2- Press **Shift** (white key): The contextual menu is displayed.



- 3- Insert the contact using the **Z2** (-) or **Z3** (+) keys.
- 4- Choose the required contact type (i, Q, q, M, m, T, t, ...) using keys **Z2**(-) and **Z3** (+).
- 5- Release **Shift**.
- 6- Use the **Z4** ▶ key to call-up the number.
- 7- Press **Shift**: The contextual menu is displayed.
- 8- Select the number (12,...,9, A,...) using the **Z2** (-) and **Z3** (+) keys.
- 9- Release **Shift**.

Entering a coil

- 1- Place the blinking ■ in the required position (last column) using keys **Z1** to **Z4**: ◀ ▼ ▲ ▶.
- 2- Press **Shift**: The contextual menu is displayed.
- 3- Insert the coil using the **Z2** (-) or **Z3** (+) keys.
- 4- Choose the required coil type using keys **Z2**(-) and **Z3** (+).
- 5- Release **Shift**.
- 6- Use the **Z4** ▶ key to call-up the number.
- 7- Press **Shift** (white key): The contextual menu is displayed.
- 8- Select the number using the **Z2** (-) and **Z3** (+) keys.
- 9- Release **Shift** (white key).
- 10- Use the **Z1** ◀ key to move to the coil function.
- 11- Press **Shift**: The contextual menu is displayed.
- 12- Select the function using the **Z2** (-) and **Z3** (+) keys.
- 13- Use keys **Z1** to **Z4**: ◀ ▼ ▲ ▶ to move to a new programming line.

Validating some function block coils will bring-up a function block parameter setting screen.

2. Element Entry Method

Changing an element

To change an element in an existing Ladder diagram, simply move to the element to be changed and follow the same procedure as when entering a new element.

Deleting an element

- 1- Place the blinking ■ cursor over the required element.
- 2- Press **Shift**: The contextual menu is displayed.



- 3- Use the **Menu / OK** (Del.) key to delete the element.
- 4- Release **Shift**.

Note: Generally, the deleted element must be replaced by a link.

3. Link Entry Method

Entering links between elements

Links can only be entered when the ● blinking cursor is displayed.

- 1- Place the blinking ■ cursor in the required position using keys **Z1 to Z4**: ◀ ▼ ▲ ▶.
- 2- Press **Shift**: The contact is created and the contextual menu is displayed.



- 3- Draw the link by moving the cursor to the desired location using the keys **Z1 to Z4**: ◀ ▼ ▲ ▶.
- 4- Release **Shift**.

Repeat this action as many times as necessary to link the elements together as required.

Deleting links between elements

- 1- Move the ● or the ■ cursor onto the link to delete using the keys **Z1 to Z4**: ◀ ▼ ▲ ▶.
- 2- Press **Shift**: The contextual menu is displayed.
- 3- Use the **Menu / OK (Del.)** key to delete the element.
- 4- Release **Shift**.

Replacing a link with a contact

To replace a link with a contact, simply place the ■ cursor at the required location and enter the contact as described in the section entitled: **Entering an Element**.

4. Automation Function Parameter Entry Method

When entering a Ladder diagram, you have to enter the automation function parameters. These parameter screens allow you to enter:

Functions with parameters:

- ◆ Auxiliary relays (latching),
- ◆ Discrete Outputs (latching),
- ◆ Clocks,
- ◆ Analog comparators,
- ◆ Timers,
- ◆ Counters,
- ◆ Fast counters.

Function block parameter setting can be accessed :

- ◆ When entering a Ladder diagram line,
- ◆ From the **PARAMETER** menu if the block has not been padlocked.

Regardless which parameter setting screen is displayed, the parameter entry principle is the same:

- 1- Place the blinking █ cursor on the parameter you wish to modify using keys **Z1 to Z4**: ◀ ▼ ▲ ▶.
- 2- Press **Shift**: The contact is created and the contextual menu is displayed. Press **Z4** ▶ to access the configuration menu.



The **Param** is only available if the automatic function has a parameter.

- 3- Release **Shift** : The contextual menu is displayed.

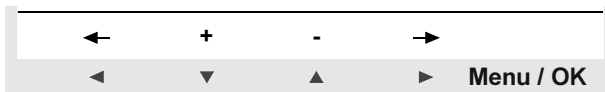

4. Automation Function Parameter Entry Method

- 4-Select the parameter to modify using the **Z1** ◀ and **Z4** keys ▶ (the selection is highlighted by the blinking of the parameter).
- 5-Modify the parameter value using the **Z2** ▼ and **Z3** ▲ keys.
- 6-Confirm and save changes by pressing **Menu / OK**. The display returns to the ladder diagram entry window.

5. Deleting and Inserting Ladder Diagram Lines

Deleting a Ladder diagram line

Ladder diagram lines are deleted line by line. The principle is as follows:

- 1- Position the cursor over an empty area of the line (no link or element) using the keys **Z1 to Z4**: ◀ ▼ ▲ ▶.
- 2- Press **Shift**: The contextual menu is displayed.



- then use the **Menu / OK** (Del.) key to delete the line.
- 3- A delete validation menu is displayed. Select the appropriate choice using the **Z2** ▼ and **Z3** ▲ keys.
 - 4- Validate the choice by pressing **Menu / OK**

The line is deleted.

Note: It is possible to delete all of the Ladder diagram lines stored in a smart relay. To do this, go to the "CLEAR PROG." option of the main menu and validate the deletion of all the lines of the Ladder diagram.

Inserting a Ladder diagram line

- 1- Position the cursor on the line immediately below the line to create using the keys **Z2** ▼ and **Z3** ▲.
- 2- Press **Shift**: The contextual menu is displayed.



- 3- Use the **Z1(ins)** key to insert the line.
- 4- Release **Shift**.



Chapter 6 - Contents

Implementing a Basic Application

- 1. Ladder Diagram Presentation _____ 105
- 2. Using the Reverse Function _____ 107
- 3. Notation Used by the Smart Relay _____ 110
- 4. Application: Implementing a Two-way Switch _____ 112

1. Ladder Diagram Presentation

In this section, we will use a simple example to understand how a Ladder diagram works: a two-way switch.

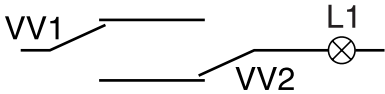
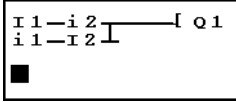
Normal electrical diagram	Ladder diagram
	
<p>The two position switches identified as VV1 and VV2 control light L1.</p>	<p>I1 and I2 are two contacts representing inputs 1 and 2 on the smart relay. Q1 is a coil that corresponds to output 1 from the smart relay.</p>

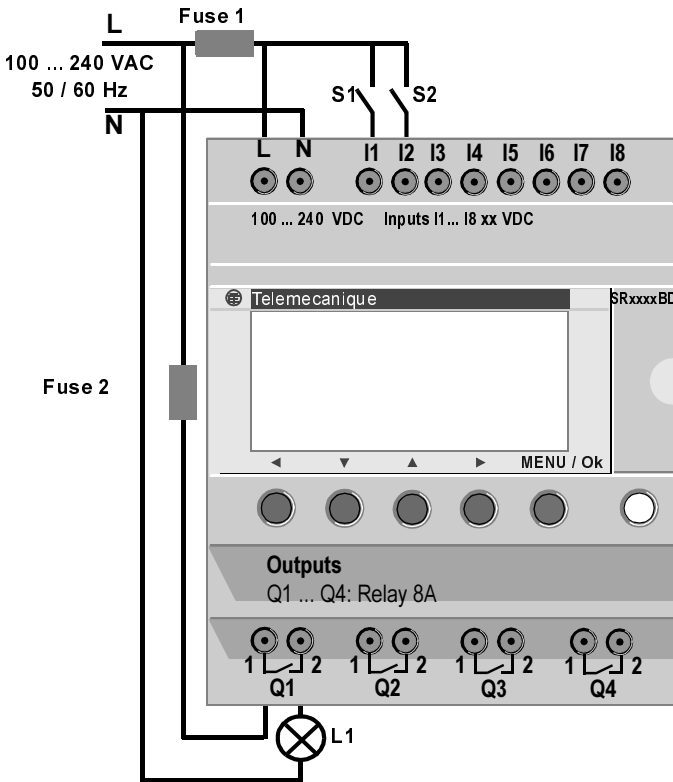

1. Ladder Diagram Presentation

Using a smart relay means that ordinary switches (with open or closed positions) can be used in place of two position switches.

The switches are identified as **S1** and **S2** in the wiring diagram above.

S1 and **S2** are connected to inputs **I1** and **I2** on the smart relay.

The operating principle is as follows:

Each time inputs **I1** and **I2** change state, this causes a change in state on output **Q1** which controls light **L1**.

The Ladder diagram uses basic features like placing contacts in parallel and in series along with the reverse function identified as **i1** and **i2** (the reverse function is described on the next page).

Note: **The implementation of a two-way switch is optimum when remote control relay coils are used** (See Chapter 4 Section 3: Discrete Outputs).

2. Using the Reverse Function

Practical example

The reverse function and its *i* notation in the smart relay is used to obtain the reverse state of input *I* wired on the smart relay. To illustrate how this function works, let us use a simple electrical diagram:

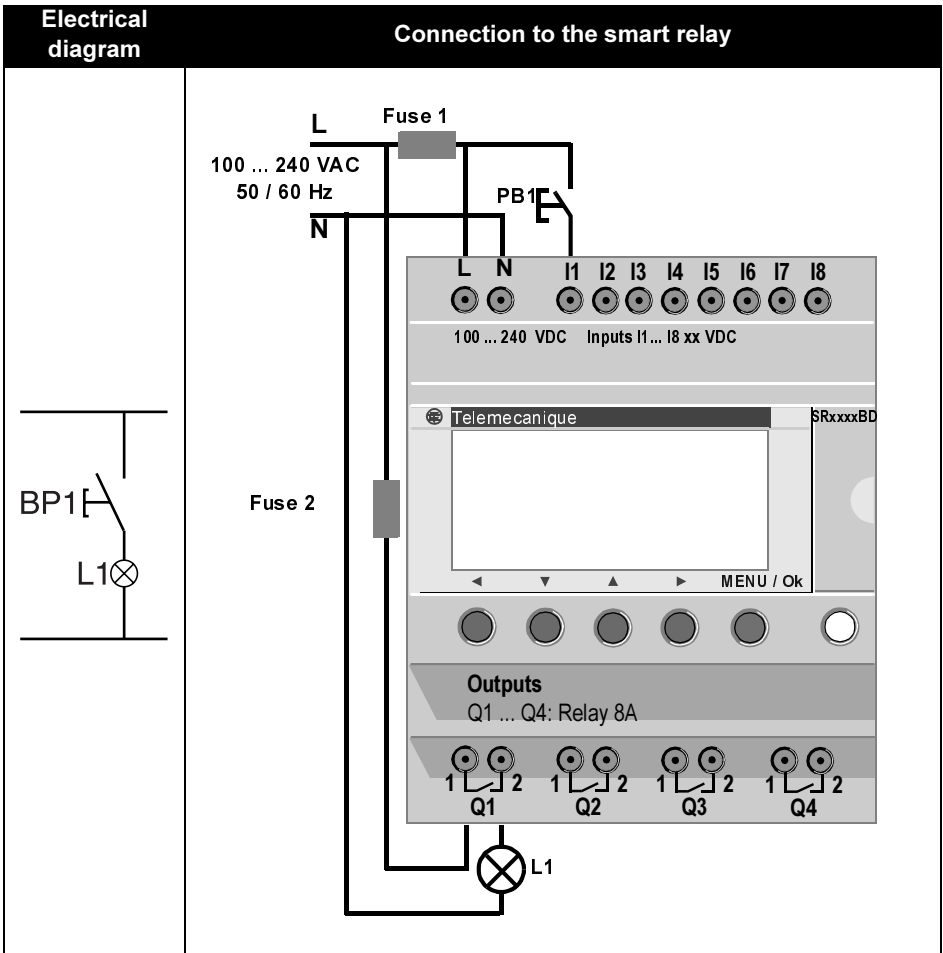

2. Using the Reverse Function

Depending on the Ladder diagram, two solutions are possible:

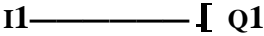
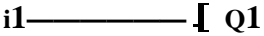
Ladder diagram 1 Light out when idle	Ladder diagram 2 Light lit when idle
	
<p>I1 corresponds to the true image of PB1, pressing PB1 activates input I1 so that the Q1 output is activated and light L1 lights.</p>	<p>i1 corresponds to the reverse image of PB1, pressing PB1 activates input I1 and therefore contact i1 is disabled, output Q1 is disabled and light L1 goes out.</p>

2. Using the Reverse Function

General case

The table below illustrates the operation of a pushbutton connected to the smart relay. Pushbutton **PB1** is connected to input **I1** and light **L1** is connected to output **Q1** on the smart relay.

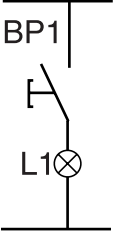
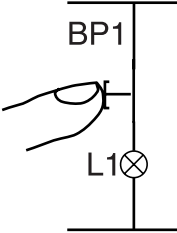
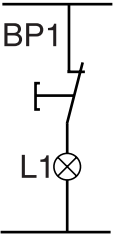
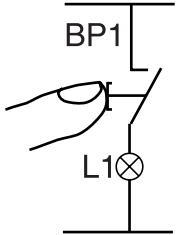





Idle		Operating	
Electrical diagram	Zelio symbol	Electrical diagram	Zelio symbol
	<p>I1 = 0</p> <p>i1 = 1</p>		<p>I1 = 1</p> <p>i1 = 0</p>
	<p>I1 = 1</p> <p>i1 = 0</p>		<p>I1 = 0</p> <p>i1 = 1</p>

Note: The reverse function applies to all of the contacts in a Ladder diagram, whether they represent outputs, auxiliary relays or function blocks.

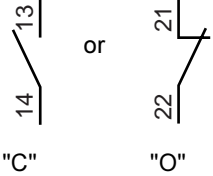
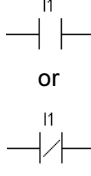
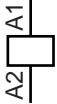
3. Notation Used by the Smart Relay

The smart relay has a four line display used to show Ladder diagrams.

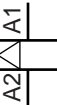
Note: The Zelio Soft 2 application lets you represent Ladder diagrams in three different formats.

Ladder diagram symbol	Ladder diagram symbol	Zelio smart relay symbol
		<p>I1 or i1</p> <p>I1 or i1</p>
		<p>I Q1</p>
 <p>Set coil (SET)</p>		<p>s Q1</p>
 <p>Reset coil (RESET)</p>		<p>R Q1</p>

3. Notation Used by the Smart Relay

Other elements are also available using a smart relay:

Timer function block: used to delay, prolong and control and action for a set length of time.

Counter function block: used to count the pulses received on an input.

Clock function block: used to trigger or release actions on precise days or at precise times.

Analog comparator function block: used to compare an analog value with a reference value or with another analog value after allowing for a hysteresis factor.

Auxiliary relays: these are used to save or relay the status of the smart relay.

Z keys: after confirming this function, Z keys can be used as pushbuttons.

Note: For more information on all of the Ladder diagram elements available when using a smart relay, refer to Chapter 4, LD Automation Functions, for a detailed description.

4. Application: Implementing a Two-way Switch



Entering the Ladder diagram

By following the indications in the table below, the user can enter the two-way switch Ladder diagram.



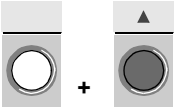

From the main screen (the one shown on power-up), follow the instructions in the " **Action** " column and press the specified button.

The " **Screen** " column shows what the user will see on the smart relay display screen.





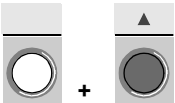
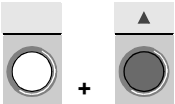

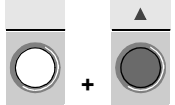









The " **Comments** " column provides some additional information on entry and display actions.

Action	Screen	Comments
	PROGRAMMING PARAMETER RUN / STOP CONFIGURATION	Position the cursor on PROGRAMMING; it will blink when selected
	■ LINE 2 LINE 3 LINE 4	After briefly displaying : LINE 1 (for approx. two seconds), a blinking ■ cursor is displayed.
	ins - + Del.	The contextual menu is displayed
	I1	The blinking ■ cursor is positioned on the I . The smart relay prompts you to select the type of contact.







4. Application: Implementing a Two-way Switch

Action	Screen	Comments
	I1	The 1 blinks. The user has implicitly selected a contact assigned to an input (I), the smart relay now prompts the user to select the input number.
	I1 •	The • blinks, indicating a link point for linking connections.
	I1 ■	The ■ blinks. You have just validated the contact entry to assign to input I1 . The ■ is moved ready to enter the second contact.
	I1—I1	The right hand I blinks. The smart relay prompts you to select the type of contact.
	I1—i1	The i blinks. You have just selected the reverse contact assigned to an input.
	I1—i1	The 1 on the right blinks. Now enter the input number.
	I1—i2	The 2 blinks.

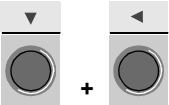
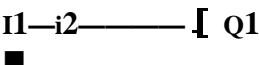
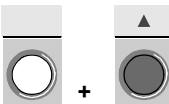

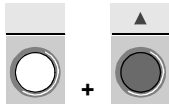
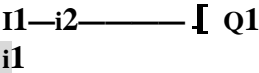

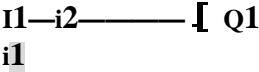
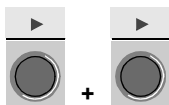

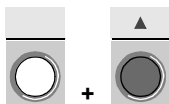
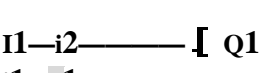
4. Application: Implementing a Two-way Switch

Action	Screen	Comments
 11 times	I1—i2 ● I1—i2 ■ ... then I1—i2 ■	The cursor blinks on ● then ■ in succession: ● link point ■ contact point Until positioned at the end of the line ready to enter the coil.
 + 	I1—i2  M1	The  blinks
	I1—i2  M1	The M blinks.
 +  2 times	I1—i2  Q1	The Q blinks.
 2 times	I1—i2 ●  Q1	The ● cursor appears
 +  3 times	I1—i2   Q1	The link is created

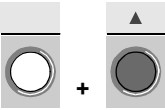

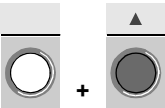
4. Application: Implementing a Two-way Switch

Action	Screen	Comments
 <p>as many times as necessary until positioned at start of line</p>		The ■ is at the start of the following line.
		The I located on the second line blinks.
		The i located on the second line blinks.
		The 1 located on the second line blinks.
		The ■ blinks.
		The I located on the second line blinks.

4. Application: Implementing a Two-way Switch

Action	Screen	Comments
	<pre> i1-i2----- Q1 i1-i1 </pre>	The second 1 in the second line blinks.
	<pre> i1-i2----- Q1 i1-i1 </pre>	The 2 located on the second line blinks.
	<pre> i1-i2----- Q1 i1-i2 </pre>	The • blinks. This shows that it is possible to connect a link at this point.
	<pre> i1-i2----- Q1 i1-i2- </pre>	The • has changed into a which operates the link between the two lines.
<p>Menu / OK</p> 	<pre> CONFIRM CHANGES ? Y E S N O </pre>	Now validate the changes. YES blinks.
<p>Menu / OK</p> 	<pre> PROGRAMMING PARAMETER RUN / STOP CONFIGURATION </pre>	The main menu re-appears. I/O is selected (blinks)
 2 times	<pre> PROGRAMMING PARAMETER RUN / STOP CONFIGURATION </pre>	RUN/STOP is selected (blinks)

4. Application: Implementing a Two-way Switch

Action	Screen	Comments
<p data-bbox="232 252 353 277">Menu / OK</p> 	<pre data-bbox="463 256 617 341"> RUN PROG ? YES NO </pre>	<p data-bbox="770 288 1014 314">Now start the program.</p>
<p data-bbox="232 411 353 437">Menu / OK</p> 	<pre data-bbox="456 411 740 512"> 1 2 3 4 B C D E S T O P L D T H U 2 5 S E P 1 6 : 4 0 1 2 3 4 </pre>	<p data-bbox="770 416 975 474">The main menu re-appears.</p>

4. Application: Implementing a Two-way Switch

This simple application example teaches the user how to enter a Ladder diagram. The following points should be remembered :

When a ■ or a ● blinks, use the **Shift** button to add an element (contact, coil or graphic link element).

When an element blinks (I, Q, No., ■, etc.), it is possible to use the **Shift + Z2** and **Z3** arrows on the arrow key pad to select the required element.

It is also possible to use the **Z1** to **Z4** arrows on the arrow key pad to move around the ladder diagram.



Chapter 7 - Contents

Debugging

- 1. Introduction _____ 121
- 2. Dynamic Mode Ladder Diagrams _____ 122
- 3. Dynamic Mode Function Block Parameters _____ 124
- 4. Dynamic Mode Menus _____ 126
- 5. Smart Relay Reaction to a Power Break _____ 127

1. Introduction

Once an application has been entered in Ladder diagram form, debugging tests still remain to be run.

The first step is to set the smart relay to RUN. To do this, select the "RUN/STOP" option from the main menu and validate the RUN mode selection made.

From this moment on, the smart relay handles the physical inputs and outputs according to the instructions entered in the Ladder diagram.

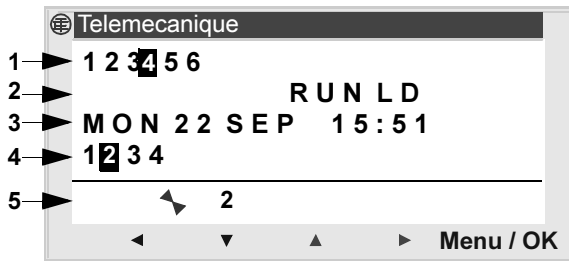

- 1 – Input status display
- 2 – Displays the run mode (RUN/STOP) and the mode in use
- 3 – Displays the date and time for products with clock
- 4 – Output status display
- 5 – Contextual menu / pushbuttons / icons indicating the operating modes

When inputs or outputs are activated, they appear in reverse video (using white on a black background).

This concept is referred to as the dynamic operation of smart relay functions. The terms RUN and dynamic have a similar meaning in the remainder of this publication.

Description of icons in the contextual menu

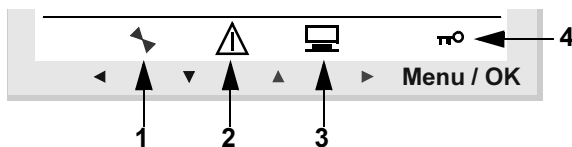

- 1 – Module status: In RUN it is in motion, in STOP it is immobile
- 2 – Indicates that faults have appeared (see FAULT menu)
- 3 – Indicates that the module is connected to the workshop
- 4 – The key indicates that the program is password-protected

2. Dynamic Mode Ladder Diagrams

Displaying Ladder diagrams

Note: Accessible in LD / RUN mode only.

The smart relay can dynamically display the performance of a Ladder diagram. To do so, simply call up the "**MONITORING**" menu and select the lines to display using the cursor keys.

Each closed contact or energized coil is displayed in reverse video mode (using white on a black background).

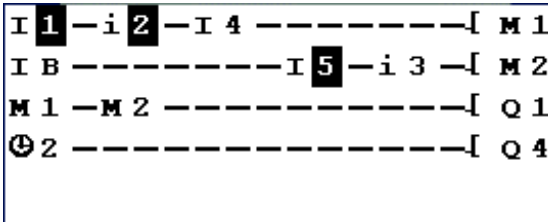

To change smart relay performance, the user can change or display some of the function block parameters.

Changing Ladder diagrams

It is **ABSOLUTELY IMPOSSIBLE** to change Ladder diagram lines in RUN mode.

It is however possible to change function block parameters in **MONITORING** mode.

Using Z keys as pushbuttons

On the **INPUTS-OUTPUTS** screen, if the function is enabled, the key number is displayed in the contextual menu at the bottom of the screen when the shift key is pressed.

To activate the key, simply select the required key ← ↑ ↓ →.

2. Dynamic Mode Ladder Diagrams

Note: The number of the keys used in the program are displayed.
Illustration

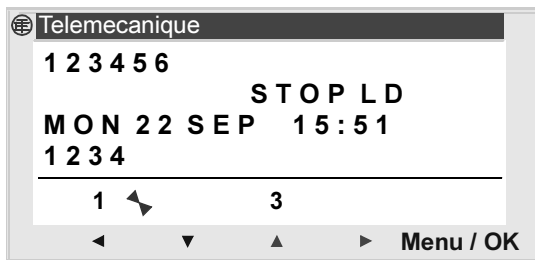

Note: The function is inactive in **PARAMETERS**, **MONITORING** mode and in all of the function block parameter screens and configuration screens.

3. Dynamic Mode Function Block Parameters

Presentation

In RUN mode a function block preset value can be changed dynamically if it is not locked.

Functions with parameters in LD mode:

- ◆ Auxiliary relays (latching),
- ◆ Discrete Outputs (latching),
- ◆ Clocks,
- ◆ Analog comparators,
- ◆ Timers,
- ◆ Counters,
- ◆ Fast counters.

Functions with parameters in LD mode:

- ◆ Numerical Constant-Type Inputs,
- ◆ Clock,
- ◆ Gain,
- ◆ Timers: TIMER A/C, TIMER B/H, TIMER Li,
- ◆ Counter: PRESET COUNT / UP DOWN COUNT,
- ◆ H-SPEED COUNT fast counter,
- ◆ PRESET H-METER hour counter,
- ◆ CAM block,

Accessing / Modifying parameters

Parameters can be accessed from the following screens:

- ◆ **MONITORING**: on the Ladder diagram,

Steps	Description
1	Use the arrow keys to move to the element you would like to modify.
2	Press the Shift and Param keys at the same time to open the parameters window.
3	Use the arrow keys to move to the modifiable parameter fields: ←→.
4	Modify the parameter value using the + and - keys, while keeping the Shift key pressed down.
5	Validate the modifications by pressing Menu/OK , which opens the validation window. Validate Menu/OK again to save the modifications.

3. Dynamic Mode Function Block Parameters

- ◆ **PARAMETER:** if the function block is not padlocked.
(See Chapter 2-Description of Menus / 4.Parameters Menu)

4. Dynamic Mode Menus

Some menus are accessible in RUN mode, while others are not. Here is a summary table.

Menu	LD	FBD
PROGRAMMING		
MONITORING	X	
PARAMETER	X	X
RUN / STOP	X	X
CONFIGURATION		
PASSWORD		
FILTER		
Zx KEYS		
CHANGE D/T		
CHANGE SUMM/WINT		
WATCHDOG CYCLE		
CLEAR PROG.		
TRANSFER		
VERSION	X	X
LANGUAGE	X	X
FAULT	X	X

5. Smart Relay Reaction to a Power Break

A power break may cause the smart relay to restart and lose any data not saved.

Smart relays have the ability to save the current time for at least 10 years.

In addition, it is also possible to back up the variables configured with the **Latching** option and defined in the parameters window.

This function can be used to save the state of the current values in the event of a power outage for:

LD Mode

- ◆ Auxiliary relays (latching),
- ◆ Discrete Outputs (latching),
- ◆ Timers,
- ◆ Counters,
- ◆ Fast counter.

FBD Mode

- ◆ AC, BH, Li timer,
- ◆ Cam programmer function CAM BLOCK,
- ◆ PRESET COUNT, UP DOWN COUNT counter,
- ◆ PRESET H-METER hour counter,
- ◆ Data archiving function ARCHIVE,
- ◆ Fast counter.

5. Smart Relay Reaction to a Power Break

Safety mode

If the result of losing the time setting is to lock coil control, then simply use a clock contact without a stop order in series with the action coils.

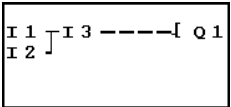
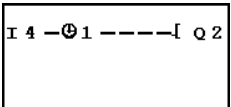
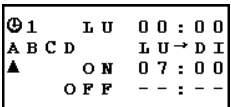
Screen	Comments
 <pre> I 1 ┌── I 3 ───┐ [Q 1 I 2 └──┘ </pre>	<p>The contact line for coil Q1 will be active even if the time and date setting is lost.</p>
 <pre> I 4 ─ 1 ─── [Q 2 </pre>	<p>The contact line for coil Q2 will only be active after setting the clock.</p>
 <pre> ⊙ 1 L U 0 0 : 0 0 A B C D L U → D I ▲ O N 0 7 : 0 0 O F F - - : - - </pre>	<p>Parameter setting screen for clock function block 1.</p>



Chapter 8 - Contents

Application Example

1. Specifications	131
2. Specification Analysis	132
3. Implementing the Solution	133

1. Specifications

The specification seeks to enhance and centralize the control system in the underground car park of an office building. The vehicle entrance and exit to and from the car park are controlled by a typical automatic barrier that handles the standard functions such as opening and closing time delays to allow vehicles to pass, processing payment tickets, a built-in security interphone, external barrier locking in the closed position...

In addition, the new specification calls for adding a function to count the number of vehicles parked in the car park and control a light up display informing users that all of the parking spaces are taken and stopping new entries by locking the barrier in the closed position. Drivers then know to look for a parking space elsewhere. It must also be possible to override this function when it is necessary to allow the emergency services to intervene (fire department, emergency medical service...).

The specification also calls for inhibiting access to the car park outside of working hours and to allow the security personnel to override this function for exceptional events. The normal working hours are: Monday to Friday from 08:30 to 17:30, Saturday from 09:30 to 12:00 and closed all day on Sunday.

For safety reasons, it is also necessary to exhaust toxic emissions such as carbon dioxide using a fan when the concentration levels measured exceed permissible levels (using a dedicated sensor that provides an output value between 0 and 10V).

There is also a requirement to control lighting triggered by a vehicle arriving and through pushbutton switches placed near all of the pedestrian access points. For power saving reasons, the lighting will be switched off after a delay of 10 minutes, the length of time normally observed to be adequate for a user to park, leave their vehicle and take the elevator or return to their vehicle and leave the car park.

To complement this system, manual intervention should allow updating the number of vehicles in the car park by incrementing or decrementing the number of vehicles as determined by the smart relay.

2. Specification Analysis

Smart relay label	Description
Input I1	Vehicle entry detection.
Input I2	Vehicle exit detection.
Counter C1	Counts the number of vehicles in the car park (93 maximum).
Output Q1	Indicates when the car park is full.
Output Q2	Locks the entry barrier (inhibits entry barrier opening) when the car park is full or outside of opening hours.
Function key Z4	Manually releases the entrance barrier.
Function key Z2	Resumes automatic entry control.
Function key Z1	Manually increments the number of vehicles in the car park.
Function key Z3	Manually decrements the number of vehicles in the car park.
Clock function block No. 1	Manages car park access hours.
Inputs I3 and I4	Pushbuttons at pedestrian access points used to light car park lighting. One for the elevator and one for the stairway (no pedestrian access is allowed via the vehicle entrance).
Output Q3	Control lighting.
Timer function block No. 1	Lighting timer (10 minutes).
Analog input IB	Carbon dioxide level sensor.
Analog function block AI , the authorized threshold value corresponds to 8.5 Volts.	Compares the carbon dioxide level measured with the allowable threshold.
Output Q4	Controls the polluted air extraction fan control.
Timer function block No. 2	Fan timer (15 minutes).

Note: To implement this solution, a smart relay with analog inputs, Clock function blocks and at least four discrete inputs and outputs.

3. Implementing the Solution

Implementing the Ladder diagram

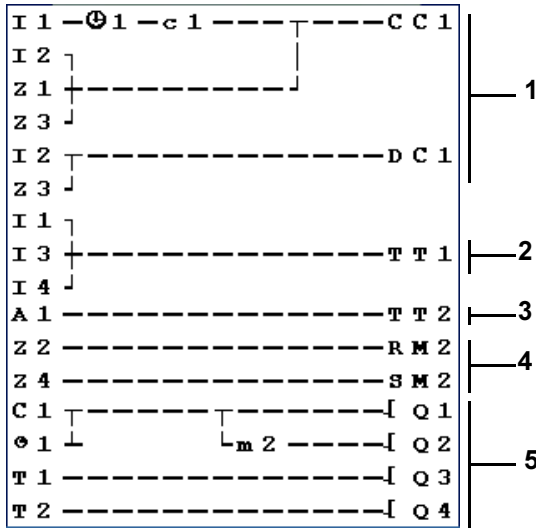

Description	
1	Counting vehicles in, subtracting vehicles out and manually updating the number of vehicles actually in the car park.
2	Starting the lighting timer.
3	Starting the fan timer.
4	Handling the manual release function.
5	Controlling outputs: car park full indicator, blocking the entrance, lighting the car park and running the extraction fan.

When upcounting and downcounting, the counter locks up when the car park becomes full (no spurious detection or counting actions take place if vehicles are allowed to enter in manual release mode). **IMPORTANT:** For a given counter, the CC and DC coils should only appear once in a Ladder diagram.

In addition, output Q2 is triggered when entry into the car park is not allowed. This leads to the use of an auxiliary relay to manually lock or unlock the access barrier using the arrow keys.

3. Implementing the Solution

Configuring the Function Blocks

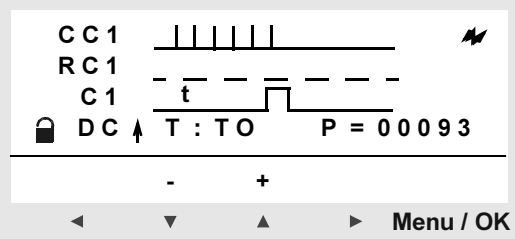
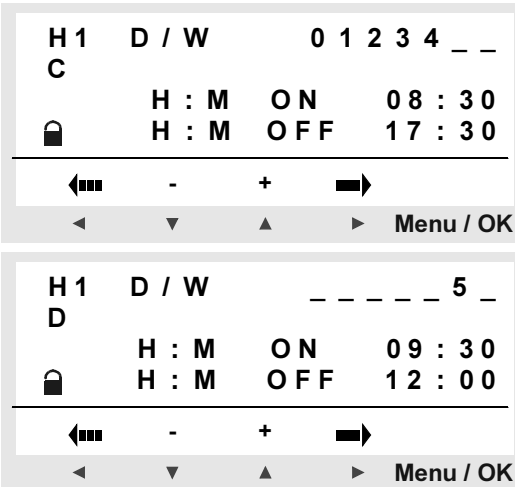
Function block	Comments
<p style="text-align: center;">Counter function block C1</p> 	<p>The preset value is 93 (the maximum number of vehicles allowed in this car park).</p> <p>Where necessary, this value can be changed during operation.</p>
<p style="text-align: center;">Clock function block 1</p> 	<p>Opening hours:</p> <ul style="list-style-type: none"> ◆ Monday to Friday from 08:30 to 17:30, ◆ Saturday from 09:30 to 12:00 ◆ closed all day on Sunday. <p>Two ranges are used.</p>

3. Implementing the Solution

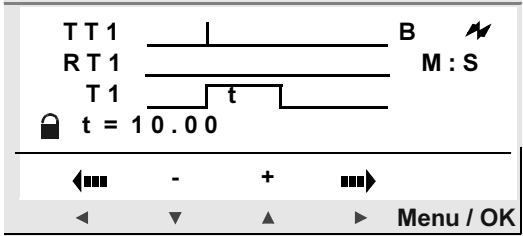
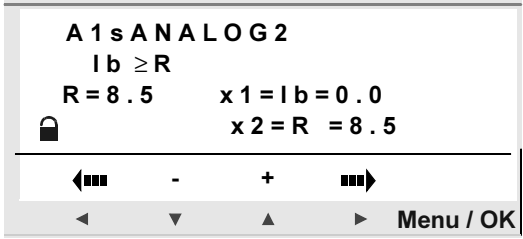
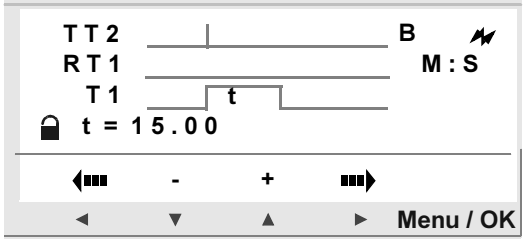
Function block	Comments
<p style="text-align: center;">Timer function block T1</p> 	<p>Car park lighting timer: 10 minutes.</p>
<p style="text-align: center;">Analog function block A1</p> 	<p>Compares the measured carbon dioxide level with the threshold value: 8.5 V.</p>
<p style="text-align: center;">Timer function block T2</p> 	<p>Fan operating duration if the carbon dioxide threshold is exceeded: 15 minutes.</p>

Chapter 9 - Contents

Troubleshooting

- 1. Smart Relay Messages _____ 137
- 2. Frequently Asked Questions _____ 138

1. Smart Relay Messages

Explanation of the messages returned by the smart relay. These messages generally indicate incompatible actions requested by the user.

Message	Cause	Corrective action
NO PARAMETER	User requested access to a PARAMETER option but no parameters are available. (the diagram does not contain any elements with parameters)	
TRANSF.ERR.	A transfer was in progress and the link with the PC went down unexpectedly.	Refer to the documentation for the smart relay PC programming application called ZelioSoft .
TRANSFER ERROR: NO MEMORY	A transfer to the EEPROM was requested and the EEPROM is not present or incorrectly located.	Check the presence and correct location of the EEPROM.
TRANSFER ERROR: CONFIG INCOMPAT	The user requested the transfer of a program that does not match the characteristics of the target smart relay. E.g. (different clocks, analog inputs, software version level).	Check the origin of the program to transfer and choose a program that is compatible with the appropriate smart relay.
TRANSFER ERROR: VERSION INCOMPAT	This error occurs if one of the smart relay versions does not correspond to requirements: firmware, LD or FBD functions	Check the firmware version used.
Outputs are displayed blinking on the main screen	One or more static outputs have shorted or overloaded.	Troubleshoot, then stop the smart relay to end the blinking before selecting RUN mode again (automatic reset)

2. Frequently Asked Questions

To assist the user in understanding the smart relay, the table below details frequently asked questions.

Question	Answer
I cannot access some parameters.	Some parameters are not accessible, refer to the documentation to determine whether these elements can be changed. Example of an element that cannot be changed : Counter function block counting direction. This element is only accessible by wiring in a Ladder diagram line.
I still cannot access some parameters	To access the parameters, use the ← and → arrow keys to select them. The ↑ and ↓ keys are used to change their value. Then press Menu/OK to accept modifications.
I cannot RUN my smart relay despite validating the RUN/ STOP option in the main menu using the Menu/ OK key.	CAUTION: check that the error symbol (!) is not displayed in the contextual menu line. Correct the error to be able to RUN the relay.
I would like to change my Ladder diagram lines but the Menu/ OK key no longer works.	Ensure that the smart relay is indeed stopped. Changes in RUN mode are not allowed.
When I try to change my Ladder diagram lines, the smart relay shows me a screen with line numbers (LINE No.) only. Have I lost all my work?	Not necessarily, this situation may occur if blank lines or 4 successive lines have been inserted at the start of the Ladder diagram.

2. Frequently Asked Questions

Question	Answer
I have a Ladder diagram that uses a Z key (←↑↓→) as a pushbutton. I would like to test it but when I display the Ladder diagram in RUN, the Z key is no longer operational. What can I do?	No this is impossible.
I generated a Ladder diagram on a module with a clock function. Can I use a backup memory to transfer it to a smart relay without a clock?	No this is impossible.
When entering a Ladder diagram, the Clock function blocks do not appear when choosing the contacts. Is this normal?	It is highly probable that the smart relay does not have a clock and that therefore the Clock function blocks cannot be accessed. Check the product reference numbers.
When entering a Ladder diagram, the Analog function blocks do not appear when choosing the contacts. Is this normal?	It is highly probable that the smart relay does not have analog inputs and that therefore Analog function blocks cannot be accessed. Check the product reference numbers.

Chapter 10 - Contents

Transferring Ladder Diagrams

1. How to Transfer an Application _____	141
2. How to Transfer an Application _____	143

1. How to Transfer an Application

Description

This function is used to:

- ◆ Load the application contained in the module into the backup memory,
- ◆ Load an application stored in the backup memory onto the module.

The program can then be loaded onto another module from this backup memory.

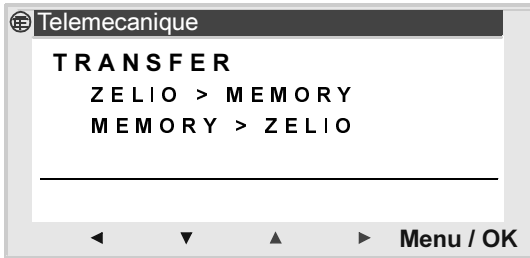

Note: The backup memory is available as an option.

Note: If the program is protected (key displayed), the user must enter a password before being able to back up the program.

Note: If an application is already present in the backup memory, it will be overwritten by the new transfer (no test is performed to check the memory is free).

1. How to Transfer an Application

Smart Relay -> Backup Memory Transfer

Transfer procedure:

Steps	Description
1	Select the transfer type: ZELIO>MEMORY using the arrow keys ↑ ↓.
2	Confirm the transfer command with the Menu/OK key. (Enter the password if the program is password-protected).
3	Wait until the transfer is complete. The following is displayed: > > MEMORY then TRANSFER. OK when it is complete.
4	Confirm a second time by pressing Menu/OK to exit the menu. Result: the display returns to the INPUTS-OUTPUTS screen in RUN mode and to the MAIN menu in STOP mode.

Backup Memory Transfer → Module

Transfer procedure:

Steps	Description
1	Select the transfer type: MEMORY>ZELIO using the arrow keys ↑ ↓.
2	Confirm the transfer command with the Menu/OK key.
3	Wait until the transfer is complete. The following is displayed: > > MODULE then TRANSFER. OK when the transfer is complete.
4	Confirm a second time by pressing Menu/OK to exit the menu. Result: the display returns to the INPUTS-OUTPUTS screen in RUN mode and to the MAIN menu in STOP mode.

2. How to Transfer an Application

Note: The comments fields and any notes entered in the ZelioSoft programming application are not transferred to the smart relay and will therefore be lost when a logic module is transferred to a PC.

Possible Errors

◆ **No backup memory**

Error message: TRANSFER ERROR: NO MEMORY

◆ **Configuration of program to be transferred incompatible with hardware configuration**

Error message: TRANSFER ERROR: CONFIG INCOMPAT (hardware or software reference numbers)

Refer to the FAULT menu to consult the error number and clear it.

11. Forms

Clock Function Block

⌚ ABCD █
-
ON:
OFF:

⌚ ABCD █
-
ON:
OFF:

⌚ ABCD █
-
ON:
OFF:

⌚ ABCD █
-
ON:
OFF:

Counter Function Block

C █
DC █

C █
DC █

C █
DC █

C █
DC █

Timer Function Block

T █
Type █









T █
Type █

T █
Type █









T █
Type █

11. Forms

Analog Function Block

<p>A </p> <p><input type="text"/></p> <p>Analog </p>	<p>A </p> <p><input type="text"/></p> <p>Analog </p>	<p>A </p> <p><input type="text"/></p> <p>Analog </p>	<p>A </p> <p><input type="text"/></p> <p>Analog </p>
--	--	--	--

Arrow Keys

<p>Z1 </p> <p><input type="text"/></p> <p></p>	<p>Z2 </p> <p><input type="text"/></p> <p></p>	<p>Z3 </p> <p><input type="text"/></p> <p></p>	<p>Z4 </p> <p><input type="text"/></p> <p></p>
--	--	--	--

Index

A

Analog

- contact 83

Auxiliary Relays 54

B

Behavior 54

C

Clock

- contact 56

- entry 59

- number 56

- operation 56, 66

Coil

- entry 97

- output 51

- remote control relay 51, 52

- RESET 51

- SET 51

Coils

- timer 61, 74

Connection

- PC 6

Contact

- analog 84

- clock 56

- counter 60, 67, 74

- entry 97

- input 50

- output 51, 56, 60, 61, 66, 67, 68, 74, 75, 83, 87

- timer 66, 88, 89

Counter

- incrementation 61, 68

- number 60, 68

- preset 62, 69

- reset 61, 68

D

Date

- modification 13

Debugging 121

E

Electrical diagram

- notation 110

Example

- specifications 131

F

- Function block
 - clock 56
 - counter 60
 - timer 74

I

Ini. 12

Inputs

- contact 50
- discrete 50
- display 6

K

Key

- pushbutton 6
- Z 55, 122

L

Ladder diagram

- deletion 102
- display in RUN 122
- entry 112
- No. of lines 49
- notation 110
- operation 105
- practical example 133

Language

- choice 12

Link

- entry 99

M

Main Menu

- description 17

Menu

- in RUN 126

Messages 137

N

NO PARAMET. 137

O

Outputs

- coil 51
- contact 51
- discrete 51
- number 51

P

Parameters

- analog 86
- clock function block 57
- entry 100

Preset

- timer 75

Q

Questions 138

R

Remote Control Relay 51

T

Time

- modification 13

Time base

- timer 76

Timer

- control 75
- number 66, 74, 87, 88, 89
- preset 75
- reset 75
- type 63, 75

TRANSF.ERR 137

Transfer

- PC 141

Troubleshooting 137

Two-way switch

- entry 112

The products, equipment and services presented in this document are subject to change at any time in their presentation, operating or usage characteristics. Their description cannot be considered contractually binding.

© Copyright Telemecanique 2004. All rights reserved. This document may not be reproduced or copied, in whole or in part, in any form or by any means, whether photographic, magnetic or other, including any transcription in whole or in part that is readable on an electronic device.